



Thrust Cylinders

Series C0D and C0P

Catalogue PDE2563TCUK-ul



Features	Air cylinder	Hydraulic cylinder	Electro mechanical actuators
Overload safe	***	***	*
Easy to limit force	***	***	*
Easy to vary speed	***	***	*
Speed	***	**	**
Reliability	***	***	***
Robustness	***	***	*
Installation cost	***	*	**
Ease of service	***	**	*
Safety in damp environments	***	***	*
Safety in explosive atmospheres	***	***	*
Safety risk with electrical installations	***	***	*
Risk of oil leak	***	*	***
Clean, hygienic	***	**	*
Standardised measurements	***	***	*
Service life	***	***	*
Hydraulic system required	***	*	***
Weight	***	**	**
Purchase price	***	**	*
Power density	**	***	*
Noise level during operation	**	***	**
High force for size	**	***	*
Positioning possibilities	*	***	***
Total energy consumption	*	**	***
Service interval	*	**	***
Compressor capacity required	*	***	***

* = good, **=average, ***=excellent



Important
 Before attempting any external or internal work on the cylinder or any connected components, make sure the cylinder is vented and disconnect the air supply in order to ensure isolation of the air supply.



Note
 All technical data in this catalogue are typical data only.
 Air quality is essential for maximum cylinder service life (see ISO 8573).



WARNING

FAILURE OR IMPROPER SELECTION OR IMPROPER USE OF THE PRODUCTS AND/OR SYSTEMS DESCRIBED HEREIN OR RELATED ITEMS CAN CAUSE DEATH, PERSONAL INJURY AND PROPERTY DAMAGE.

This document and other information from Parker Hannifin Corporation, its subsidiaries and authorized distributors provide product and/or system options for further investigation by users having technical expertise. It is important that you analyze all aspects of your application and review the information concerning the product or system in the current product catalog. Due to the variety of operating conditions and applications for these products or systems, the user, through its own analysis and testing, is solely responsible for making the final selection of the products and systems and assuring that all performance, safety and warning requirements of the application are met. The products described herein, including without limitation, product features, specifications, designs, availability and pricing, are subject to change by Parker Hannifin Corporation and its subsidiaries at any time without notice.

SALE CONDITIONS

The items described in this document are available for sale by Parker Hannifin Corporation, its subsidiaries or its authorized distributors. Any sale contract entered into by Parker will be governed by the provisions stated in Parker's standard terms and conditions of sale (copy available upon request).

Contents	Page
COD and COP Thrust cylinders	4
Main data.....	5
Material specification	5
Working medium, air quality	5
Order key, Diaphragm type	6
Order key, Piston type	6
Ordering data for COD and COP thrust cylinders	7
Dimensions: piston and diaphragm type	8
Neck mounting nut and piston rod nut	9
Seal kits and grease for COD and COP	9
Press stand for thrust cylinders	10
Dimensions, press stand	11

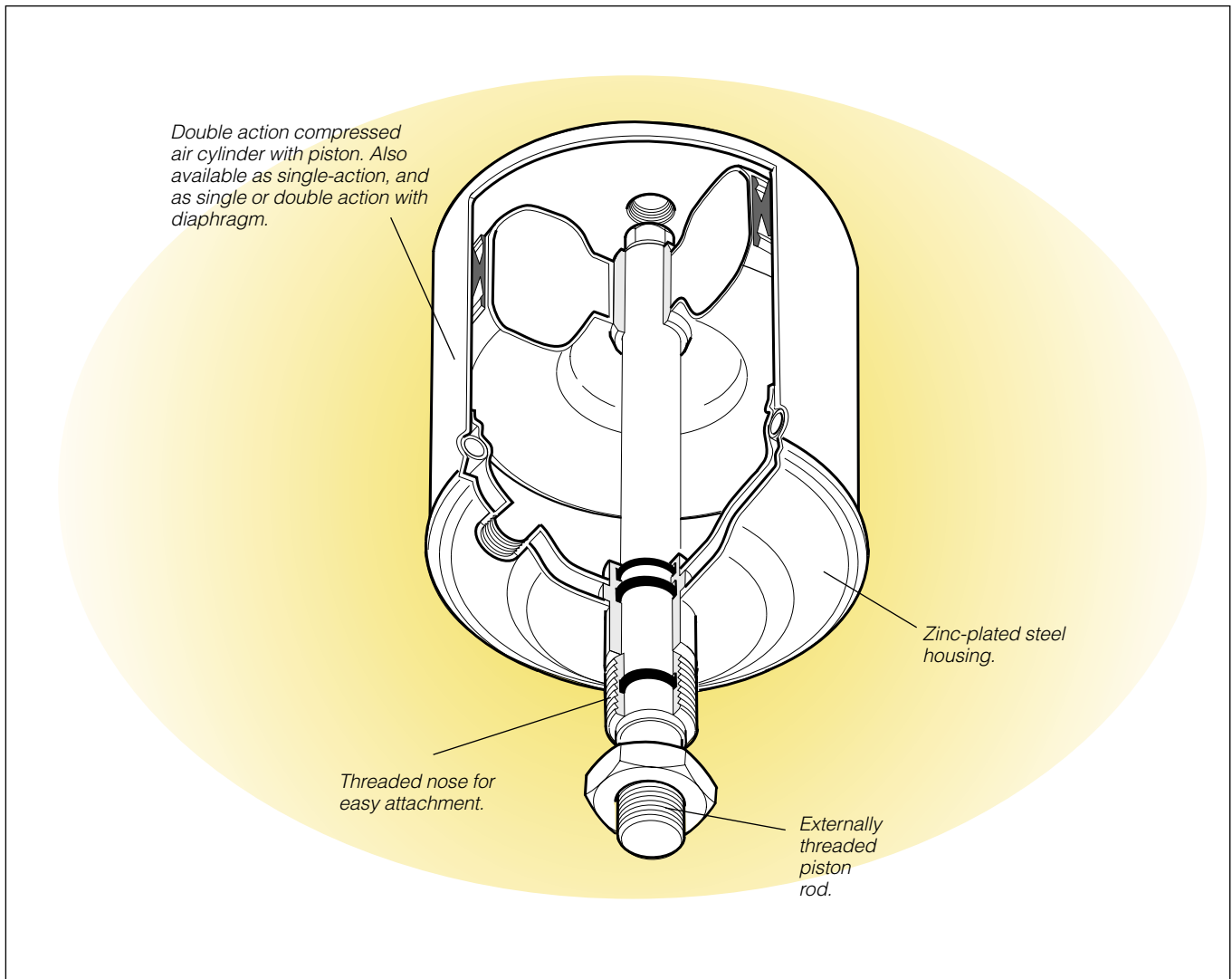

**COD and COP
Thrust cylinders**

The thrust cylinders are linear actuators, designed for a high force to size ratio. This makes the cylinder ideal to use for clamping, riveting, punching and similar applications where a high force is required.

The range includes 14 different versions, providing forces from 1600 to 25 000 N (at 6 bar), single- as well as double-acting and in piston or diaphragm design.

The single-acting version has a built in powerful spring for the return stroke, but for applications where a high force is required in both directions there is the double-acting version.

The cylinder body is an all zinc plated sheet of steel and the piston rod, which is guided in two maintenance free bearings, is provided with flats and a male thread.

To facilitate the installation, the guiding sleeve is provided with a thread which can be used either for direct mounting in a threaded hole or for installation in a free running hole using a lock nut.

Main data

Thrust cylinder	Force ¹⁾ at	Stroke ²⁾	Spring force		Weight	Displacement ³⁾		Port thread
	600 kPa (6 bar)		Max	Min		plus	minus	
	N	mm	N	N	Kgs	dm ³	dm ³	
Double acting								
COD300-40	3000	40	-	-	2,6	0,50	0,42	G1/4
COD600-50	6000	50	-	-	5,4	1,05	0,92	G1/4
COD1200-50	12000	50	-	-	11,4	1,96	1,90	G1/2
COP2500-60	25000	60	-	-	21,4	3,50	3,40	G1/2
COP2500-80	25000	80	-	-	21,6	4,40	4,30	G1/2
Single acting								
COP160-50S	1600	50	314	128	1,0	0,12	-	G1/4
COP160-80S	1600	80	314	128	1,0	0,20	-	G1/4
COP300-50S	3000	50	314	128	1,5	0,30	-	G1/4
COP300-80S	3000	80	314	128	1,5	0,50	-	G1/4
COD300-40S	3000	40	294	98	2,8	0,50	-	G1/4
COD600-50S	6000	50	638	98	5,6	1,05	-	G1/4
COD1200-50S	12000	50	981	235	12,2	1,96	-	G1/2
COP2500-60S	25000	60	2700	883	22,0	3,50	-	G1/2
COP2500-100S	25000	100	2700	883	22,2	5,40	-	G1/2

1) In the case of single-acting thrust cylinders, spring force must be considered in calculation of performance.

2) Tolerance ±3 mm (COP2500 +6/-1)

3) The displacement relates to plus and minus chambers and includes dead volume.

Additional data

Working pressure	Max 8 bar
Working temperature	-20 °C to +70 °C

Prelubricated, further lubrication is not normally necessary.
If additional lubrication is introduced it has to be continued.

Material specification

Cylinder housing	Painted steel plate
Piston	Steel
Piston rod	Steel
Piston rod nut	Steel
Diaphragm, COD	Textile reinforced nitrile rubber, NBR
Seals	Nitrile rubber, NBR
Piston rod bearings	Lubricant filled thermoplastic
Return spring	Spring steel

Working medium, air quality

Working medium Dry, filtered compressed air
to ISO 8573-1 class 3.4.3.

Recommended air quality for cylinders

For best possible service life and trouble-free operation, ISO 8573-1 quality class 3.4.3 should be used. This means 5 µm filter (standard filter) dew point +3 °C for indoor operation (a lower dew point should be selected for outdoor operation) and oil concentration 1.0 mg oil/m³, which is what a standard compressor with a standard filter gives.

ISO 8573-1 quality classes

Quality class	Pollution		Water max. press. dew point (°C)	Oil max concentration (mg/m ³)
	particle size (µm)	max concentration (mg/m ³)		
1	0,1	0,1	-70	0,01
2	1	1	-40	0,1
3	5	5	-20	1,0
4	15	8	+3	5,0
5	40	10	+7	25
6	-	-	+10	-

NOTE!

Compressed air cylinders, types COP and COD should not be used in vertical applications without an external stop.

Order key, Diaphragm type

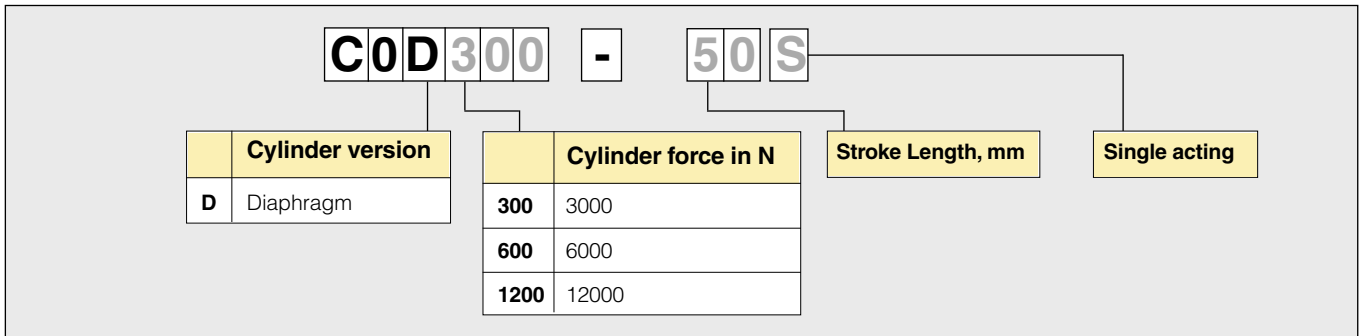

Order key, Piston type

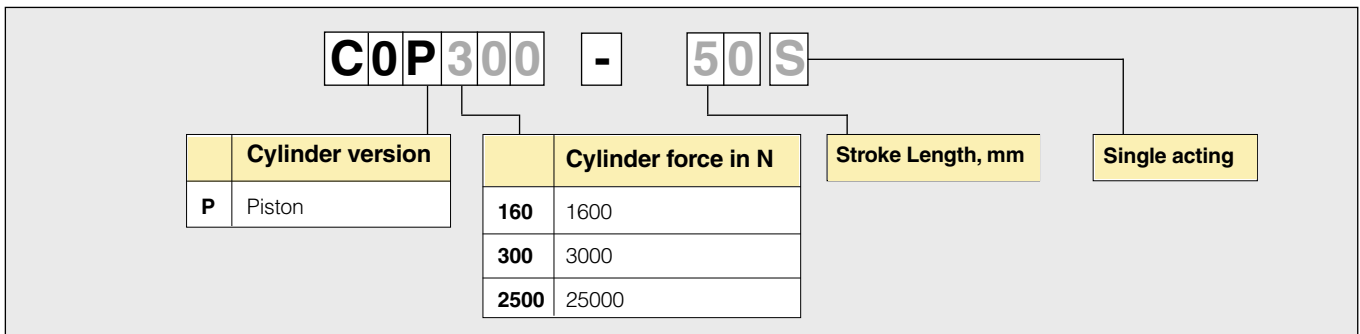



C0D

C0P

Main data for C0D and C0P thrust cylinders

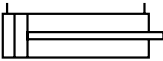
Symbol	Force at 6 bar N	Conn.	Stroke mm	Weight Kg	Order code
Double acting 	3000	G1/4	40	2,7	C0D300-40
	6000	G1/4	50	5,7	C0D600-50
	12000	G1/2	50	11,5	C0D1200-50
	25000	G1/2	60	21,4	C0P2500-60
	25000	G1/2	80	21,6	C0P2500-80

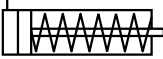
Symbol	Force at 6 bar N	Spring force Max N Min N		Conn.	Stroke mm	Weight Kg	Order code
Single acting 	1600	314	128	G1/4	50	0,9	C0P160-50S
	1600	314	128	G1/4	80	1,1	C0P160-80S
	3000	314	128	G1/4	50	1,2	C0P300-50S
	3000	314	128	G1/4	80	1,4	C0P300-80S
	3000	294	98	G1/4	40	2,8	C0D300-40S
	6000	638	98	G1/4	50	5,9	C0D600-50S
	12000	981	235	G1/2	50	12,4	C0D1200-50S
	25000	2700	883	G1/2	60	22,0	C0P2500-60S
	25000	2700	883	G1/2	100	22,4	C0P2500-100S

Thrust cylinders are supplied complete with piston rod nut.

The spring forces in single acting cylinders are sufficient to return the piston rod without load.

Dimensions: piston type

CAD drawings on the Internet

Our home page www.parker.com/euro_pneumatic includes the AirCad Drawing Library with 2D drawings for the main versions.

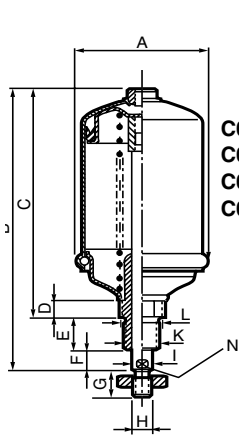

COP160-50S
COP160-80S
COP300-50S
COP300-80S

Single-acting

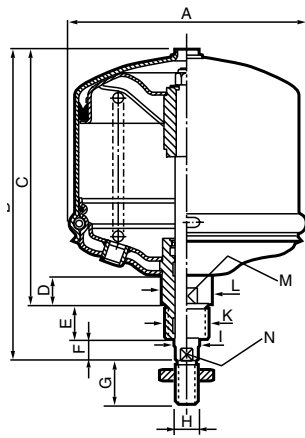

COP2500-60S
COP2500-100S

Single-acting

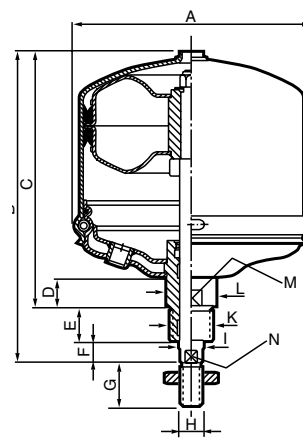

COP2500-60
COP2500-80

Double-acting

Type	Connection thread	A	B	C	D	E	F	G	H	I Ø	K	L Ø	M	N
COP160-50S	G1/4	66	192	151	18	30	11	24	M12x1,75	14	M24x3	30	30	12
COP160-80S	G1/4	66	222	181	18	30	11	24	M12x1,75	14	M24x3	30	30	12
COP300-50S	G1/4	93	192	151	18	30	11	24	M12x1,75	14	M24x3	30	30	12
COP300-80S	G1/4	93	222	181	18	30	11	24	M12x1,75	14	M24x3	30	30	12
COP2500-60S	G1/2	268	345	285	33	40	20	48	M24x3	28	M48x3	56	50	25
COP2500-100S	G1/2	268	385	325	33	40	20	48	M24x3	28	M48x3	56	50	25
COP2500-60	G1/2	268	345	285	33	40	20	48	M24x3	28	M48x3	56	50	25
COP2500-80	G1/2	268	385	325	33	40	20	48	M24x3	28	M48x3	56	50	25

Dimensions: diaphragm type

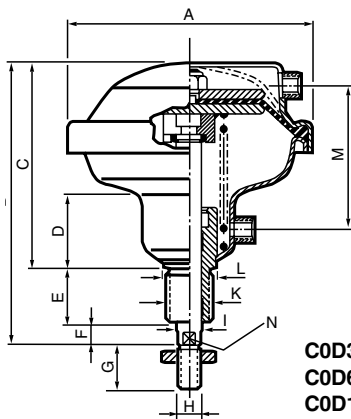

COD300-40S
COD600-50S
COD1200-50S

Single-acting

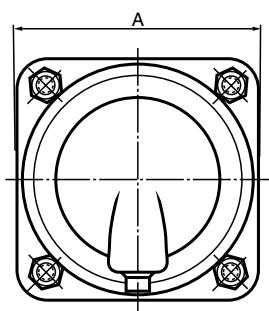

COD300-40S
COD600-50S
COD1200-50S

COD300-40
COD600-50
COD1200-50

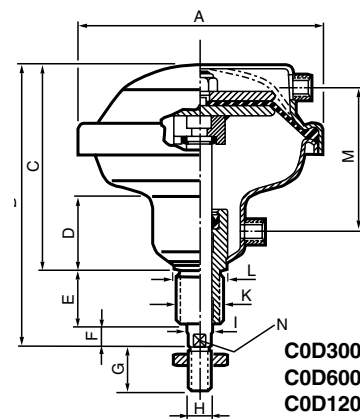

COD300-40
COD600-50
COD1200-50

Double-acting

Type	Connection thread	A	B	C	D	E	F	G	H	I Ø	K	L Ø	M	N
COD300-40S	G1/4	150	183	131	48	38	14	24	M12x1,75	16	M24x2	30	90	13
COD300-40	G1/4	150	183	131	48	38	14	24	M12x1,75	16	M24x2	30	90	13
COD600-50S	G1/4	195	212	154	55	38	20	32	M16x2	20	M36x3	43	107	17
COD600-50	G1/4	195	212	154	55	38	20	32	M16x2	20	M36x3	43	107	17
COD1200-50S	G1/2	261	243	178	58	45	20	40	M20x2,5	25	M36x3	43	117	22
COD1200-50	G1/2	261	243	178	58	45	20	40	M20x2,5	25	M36x3	43	117	22



Neck mounting nut

Neck mount. nut thread	Weight Kg	For cylinder	Order code
M24x2	0,04	COD300-40	9141100000
M36x3	0,14	COD600-50	9141100100
M36x3	0,14	COD1200-50	9141100100
M48x3	0,10	COP2500-60	9141100200
M48x3	0,10	COP2500-80	9141100200
M24x3	0,04	COP160-50S	9141100300
M24x3	0,04	COP160-80S	9141100300
M24x3	0,04	COP300-50S	9141100300
M24x3	0,04	COP300-80S	9141100300
M24x2	0,04	COD300-40S	9141100000
M36x3	0,14	COD600-50S	9141100100
M36x3	0,14	COD1200-50S	9141100100
M48x3	0,10	COP2500-60S	9141100200
M48x3	0,10	COP2500-100S	9141100200



Piston rod nut

Piston rod nut thread	Weight Kg	For cylinder	Order code
M12	0,01	COD300-40	0266211200
M16	0,02	COD600-50	0266211400
M20	0,03	COD1200-50	0266211600
M24	0,04	COP2500-60	0266211800
M24	0,04	COP2500-80	0266211800
M12	0,01	COP160-50S	0266211200
M12	0,01	COP160-80S	0266211200
M12	0,01	COP300-50S	0266211200
M12	0,01	COP300-80S	0266211200
M12	0,01	COD300-40S	0266211200
M16	0,02	COD600-50S	0266211400
M20	0,03	COD1200-50S	0266211600
M24	0,04	COP2500-60S	0266211800
M24	0,04	COP2500-100S	0266211800

Thrust cylinders are supplied complete with piston rod nut.

Seal kits for COD and COP

Description	Order code
COD300-40/-40S	9121655401
COD600-50/-50S	9121655501
COD1200-50/-50S	9121655601
COP160-50S/-80S	9121655101
COP300-50S/-80S	9121655201
COP2500-60/-80	9121655301
COP2500-60S/-100S	9121655302

Grease for COD and COP



Weight	Order code
30 g	9127394541

Press stand for thrust cylinders

A simple press for efficient mounting and pressing can easily be built by screwing the thrust cylinders into the threaded holes in the very stable and strong steel press stand. The stand is available in two versions with different fastening threads for the cylinders.

The top plate has two different threads, and can be rotated through 180 degrees to present the correct thread for nose fitting of the cylinders.

The sub-base is fitted with a T-track for easy mounting of accessories. It also has two through holes for simple and secure fitting to a work bench.



NOTE! Remember that an approved two-handed press control must be used with the cylinders and the press stand to prevent crush injuries.

We recommend the use of our type PXP two-handed press control. It is available in a number of versions, and is simple, ergonomic and safe to incorporate in the press stand. It meets the requirements of safety standards EN574 and EN954-1.

For more information, see our website:
www.parker.com/euro_pneumatic

Description	Threads A/B	Weight kg	Order No.
Press stand for COP160-50S, COP160-80S, COP300-50S, COP300-80S, COD300-40, COD300-40S and COD300-50S	M24x2/M24x3	24	COP-COD-P01
Press stand for COD600-40, COD600-50S, COD1200-50S, COD1200-80S, COP2500-60, COP2500-80, COP2500-60S and COP2500-100S	M36x3/M48x3	24	COP-COD-P02

Dimensions

