



# *Lockout Valves*

*Pneumatic system isolator  
valves with locking facility.*

*Catalogue no: 2144GB-ca*



# Lockout Valves

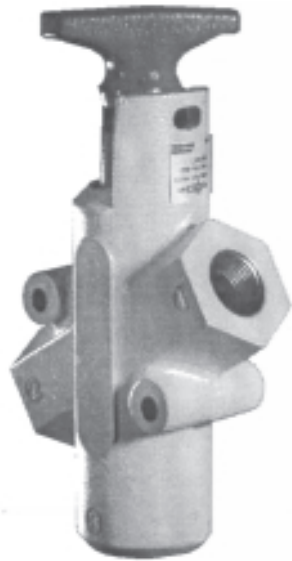

## Features

- Used in systems for compliance with OSHA Standard 29 CFR Part 1910.
- G1/4 to G1 port size.
- Cv's from 3.0 to 10.0.
- High flow G1 exhaust port all sizes.
- Rugged cast aluminium alloy body.
- Metal handle more durable than competitive plastic handles.
- Inline or surface mounting.
- Mounting holes interchangeable with 3/8" - 1/2" ISI models.
- Safety yellow and red for high visibility.
- Denteted spool
- Optional silencer installed.

## Application

Lockout valves are installed in pneumatic drop legs, or individual pneumatic control lines (see figure 1.) In accordance with OSHA procedures, lockout valves are used during maintenance and service procedures of pneumatically (air) operated equipment. Prior to servicing, the red handle is pressed inward, blocking pressure and relieving all downstream air pressure. A padlock is installed through the locking hasp, preventing accidental actuation during the maintenance procedure. Following maintenance, the padlock is removed and the red handle is pulled outward, returning air pressure to the system. (For complete lockout/tagout procedures, consult OSHA standard 29 CFR part 1910 in U.S. Federal Register /Vol. 54 no. 169, Friday, September 1, 1989/Page 36644).

Valves can be inline mounted or surface mounted using the two 8mm mounting holes provided in the valve body. Mount valves in plain view with the handle oriented for accessibility.

## Mounting

Valves can be inline mounted or surface mounted using the two 8mm mounting holes provided in the valve body. Mount valves in plain view with the handle oriented for accessibility.

## Operation

Normal Machine Operation - With the handle pulled outward. Inlet port 1 is open to outlet port 2. Exhaust port 3 is blocked.

Lockout Operation - With the handle pushed inward. Inlet port 1 is blocked. Outlet port 2 is open to exhaust port 3.

## Dimensions (mm)

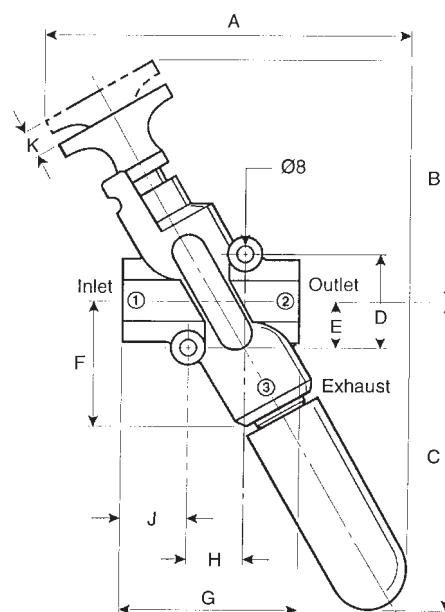

	A	B	C	D	E	F	G	H	J	K
mm	212	143	169	56	28	75	105	34	39	18

## Technical Information

Pressure range : 0 to 17 bar  
 Temperature range (ambient) : 0° to 70°C

## Materials of Construction

Body & Handle : Cast Aluminium Alloy  
 Spool : Aluminium  
 Seals : Carboxylated Nitrile  
 Dentet Spring : Stainless Steel  
 Grease : Magnalube G

## Flow Coefficiency ( $C_v$ )

Model	1 - 2	2 - 3
LV20BA	3.0	6.0
LV30BA	4.3	9.0
LV40BA	7.7	11.3
LV60BA	9.5	9.0
LV80BA	10.2	8.8

## Part Nos.

Description	Port Size (G1 exhaust)				
	G1/4	G3/8	G1/2	G3/4	G1
Standard 3/2 Lockout	<b>LV20BA</b>	<b>LV30BA</b>	<b>LV40BA</b>	<b>LV60BA</b>	<b>LV80BA</b>

Lightweight porous polythene silencer for G1 exhaust port : Part No. **500-6**

## Sample Lockout Circuit

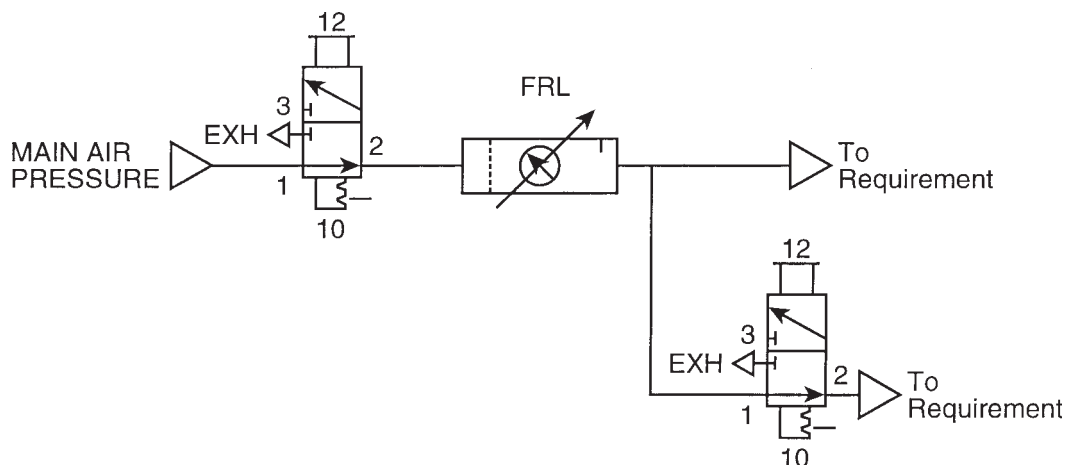

**Fig 1.**  
**Lockout Valves shown in the normally open condition**