



Shocks absorbers Series MC-SC

Catalogue : 2252UK-1-po





Contents

Description.....	4
Comparison of Damping Systems	5
Range and Selection of Shock absorbers.....	6
Formulae and calculation examples.....	7-8-9
Capacity Chart.....	10-11
General features series MC 9 M to MC 600 M and SC 925.....	12
Dimensions series MC 9 M to MC 600 M and SC 925.....	13
Accessories for series MC 9 M to MC 600 M and SC 925.....	14
General features serie MC 33 to MC 64.....	15
Dimensions serie MC 33 to MC 64.....	15
Accessories for serie MC 33 to MC 64.....	16-17

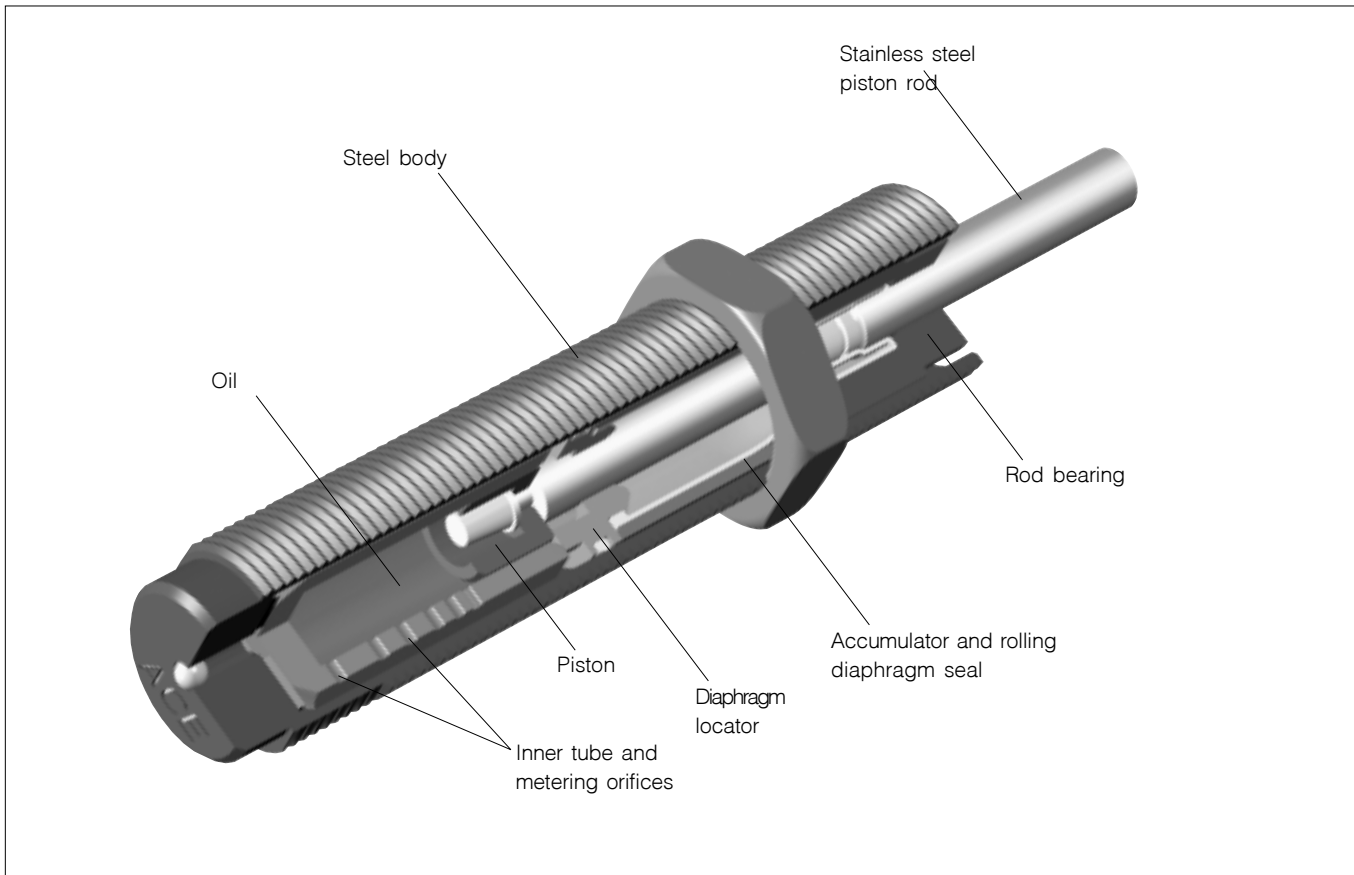

Virtually all manufacturing process involve movement of some kind. In production machinery this can involve linear transfers, rotary index motions, fast feeds, etc..
At some points these motions change direction or come to a stop.

Any moving object possesses kinetic energy as a result of its motion and if the object changes direction or is brought to rest, the dissipation of this kinetic energy can result in destructive shock forces within the structural and operating parts of the machine.

The kinetic energy increases such as an exponential function of velocity. Heaver the object is or the faster it travels, the more energy it has. An increase of production rates is only possible by dissipating this kinetic energy smoothly and thereby eliminating destructive deceleration forces.

Other methods of energy absorption such as rubber buffers, springs, hydraulic dashpots do not provide this required smooth deceleration characteristic. They are non linear and produce high peak forces at some point during their stroke.

The optimum solution is achieved by Parker shock absorbers.

Description

Shock absorbers are hydraulic units which allow to bring a moving load to rest, quickly and safely, without rebound nor backward movement.

They provide a constant linear deceleration with the lowest possible reaction force in the shortest possible stopping time.

During the impact the piston is pushed in the shock absorber. The oil pushed back through the rolling orifices is absorbed in the accumulator. Proportionally with the stroke achieved, the quantity of metering orifices decreases. This generates the slowing down of the mass and of the impact velocity.

The installation of these shock absorbers on machines :

- Increases : *productivity
*operating life of machines
- Reduces : *construction costs of the machine
*maintenance cost
*noise

A full range of accessories is available for mounting the shock absorbers.

Comparison of Damping Systems

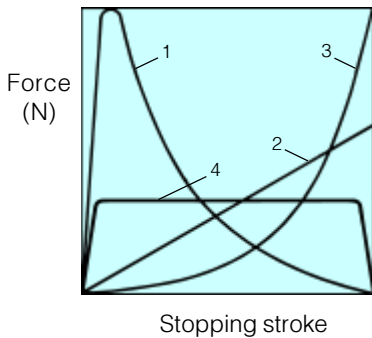

1. Hydraulic dashpot (High stopping force at start of the stroke)

With only one metering orifice the moving load is abruptly slowed down at the start of the stroke. The braking force rises to a very high peak at the start of the stroke (giving high shock loads).

2. Springs and Rubber Buffers (high stopping forces at end of stroke)

at full compression. Also they store energy rather than dissipating it, causing the load to rebound back again.

3. Air buffers, Pneumatic cylinder cushions (high stopping force at end of stroke)

Due to the compressibility of air they have a sharply rising force towards the end of stroke. The majority of energy is absorbed near the end of stroke.

4. Parker industrial shock absorbers (uniform stopping force through the entire stroke)

The moving load is smoothly brought to rest by a constant resisting force throughout the entire shock absorber stroke. The load is decelerated with the lowest possible force in the shortest possible time eliminating damaging force peaks and shock damage to machines or equipment.

Energy capacity

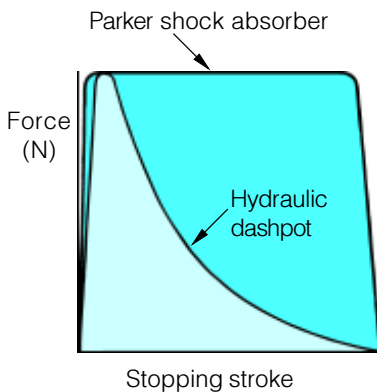

Assumption :

Same maximum reaction force

Result :

Parker shock absorber can absorb considerably more energy (represented by the area under the curve)

Benefit :

By installing a Parker shock absorber production rates can be more than **doubled without increasing deceleration forces or reaction forces** on the machine.

Reaction force (stopping force)

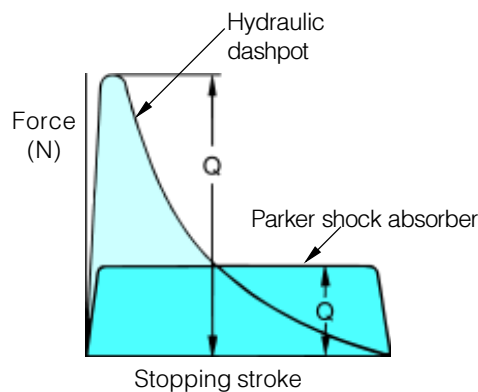

Assumption :

Same energy absorption (zone sous la courbe)

Result :

The reaction of the force transmitted by the Parker shock absorber is very much slower.

Advantage :

By installing a Parker shock absorber, **the machine wear and maintenance can be drastically reduced.**

Stopping time

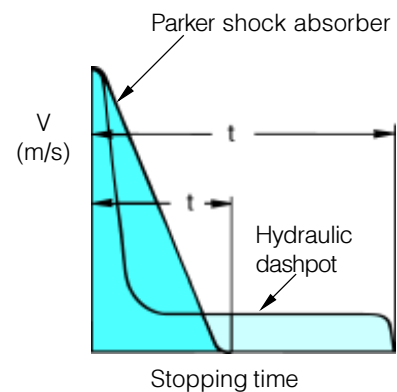

Assumption :

Same energy absorption

Result :

The Parker shock absorber stops the moving load in a much shorter time.

Advantage :

By installing a Parker shock absorber cycle times are **reduced giving much more higher production rates.**

Range

Series MC 9 M to MC 600 M

Compact and versatile, the MC serie offers many advantages. Its small size allows for high energy absorption in confined spaces, while the self-compensating design accomodate a variety of load conditions. With threaded outer body and numerous accessories, MC models can be mounted in a number of configurations.



Series SC 925

These innovative miniature shock absorbers provide dual performance characteristics and benefits in a single package. Soft contact is suggested when a low initial reaction force is required at impact. Self-compensating is utilized to obtain maximum energy absorption capacity.



Series MC 33 to MC 64

These models complete the range of medium bore shock absorbers. With their compact design and threaded outer body the MC units can be mounted in a wide variety of configurations.

The standard self-compensating models offer three ranges of effective weights providing linear deceleration throughout varying applications without adjustment.



Shock absorber selection

To select the best shock absorber for your application, follow these steps :

1/ Determine the application : use the examples **pages 7 and 8**.

2/ Use formulae of chosen examples to calculate :

- energy per cycle : **W₃**
- energy per hour : **W₄**
- effective weight : **me**

These values help to find the closest shock absorber matching your application.

3/ Chose in capacity chart pages 10 and 11 the shock absorber with greater values than **W₃, W₄** and **me**

For best results, chose a shock absorber working between 50 and 80% of max. energy (**W₃**).
Check that the effective weight **me** lies within the values of the chosen shock absorber.

4/ Check the shock absorber stroke : if it matches the stroke of your application, the shock absorber you have selected can handle your application.

Note : When using more than one shock absorber on an application, divide **me, W3 and W4** by the quantity of shock absorbers



**A CD Rom for shock absorber selection is available
on web site : www.parker.com/euro_pneumatic**

Formulae and calculation examples

It is easy to calculate around 90% of applications knowing only the 4 opposite parameters :

- | | | |
|---|----------------------|--------------|
| 1. Mass to be decelerated | m | (kg) |
| 2. Impact velocity at shock absorber | V_D | (m/s) |
| 3. Propelling force | F | (N) |
| 4. Cyles per hour | C | (1/h) |

Key to symbols used

W ₁	Kinetic energy per cycle	Nm	HM	Stall torque facto (normally 2,5)	1 to 3
W ₂	Propelling force energy per cycle	Nm	M	Propelling torque	Nm
W ₃	Total energy per cycle (W ₁ + W ₂)	Nm	J	Moment of inertia	kgm ²
W ₄	Total energy per hour (W ₃ · x)	Nm/h	g	Acceleration due to gravity = 9,81	m/s ²
me	Effective weight	kg	h	Drop height excl. shock absorber stroke	m
m	Mass to be decelerated	kg	s	Shock absorber stroke	m
n	Number of shock absorbers		L/R/r	Radius	m
*V	Velocity of moving mass	m/s	Q	Reaction force	N
*V _D	Impact velocity at shock absorber	m/s	μ	Coefficient of friction	
ω	Angular velocity	1/s	t	Deceleration time	s
F	Propelling force	N	a	Deceleration	m/s ²
x	Cycles per hour	/hr	α	Side load angle	°
P	Motor power	kW	β	Angle of incline	°

*v et V_D is the final impact velocity of the mass. With accelerating motion the final velocity can be 1,5 to 2 times higher than the average.

In all the following examples, the choice of shock absorbers made from the capacity chart is based upon the values (W₃), (W₄), me and the desired shock absorber stroke (s).

1 Mass without propelling force

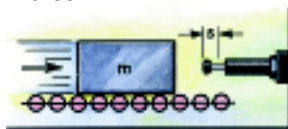

Formulae

$$W_1 = m \cdot v^2 \cdot 0,5$$

$$W_2 = 0$$

$$W_3 = W_1 + W_2$$

$$W_4 = W_3 \cdot x$$

$$V_D = v$$

$$me = m$$

Example

m = 100	kg
v = 1,5	m/s
x = 500	/hr
s = 0,05	m (chosen)

W ₁ = 100 · 1,5 ² · 0,5	=	113 Nm
W ₂ = 0		
W ₃ = 113 + 0	=	113 Nm
W ₄ = 113 · 500	=	56 500 Nm/h
me = m	=	100 kg

Chosen from capacity chart :
Model **MC 3350 M-2 self-compensating**

2 Mass with propelling force

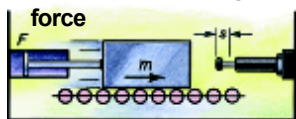

Formulae

$$W_1 = m \cdot v^2 \cdot 0,5$$

$$W_2 = F \cdot s$$

$$W_3 = W_1 + W_2$$

$$W_4 = W_3 \cdot x$$

$$V_D = v$$

$$me = \frac{2 \cdot W_3}{V_D^2}$$

$$W_2 = (F - m \cdot g) \cdot s$$

$$W_2 = (F + m \cdot g) \cdot s$$

Example

m = 36	kg
*v = 1,5	m/s
F = 400	N
x = 1000	/hr
s = 0,025	m (chosen)

W ₁ = 36 · 1,5 ² · 0,5	=	41 Nm
W ₂ = 400 · 0,025	=	10 Nm
W ₃ = 41 + 10	=	51 Nm
W ₄ = 51 · 1000	=	51 000 Nm/h
me = 2 · 51 / 1,5 ²	=	45 kg

Chosen from capacity chart :
Model **MC 600 M self-compensating**

*v is the final impact velocity of the mass. With pneumatically propelled systems this can be 1,5 to 2 times higher the average velocity.
Please take this into account when calculating energy.

3 Mass with motor drive



Formulae

$$W_1 = m \cdot v^2 \cdot 0,5$$

$$W_2 = \frac{1000 \cdot P \cdot HM \cdot s}{v}$$

$$W_3 = W_1 + W_2$$

$$W_4 = W_3 \cdot x$$

$$V_D = v$$

$$me = \frac{2 \cdot W_3}{V_D^2}$$

Example

m = 800	kg
v = 1,2	m/s
HM = 2,5	
P = 4	kW
x = 100	/hr
s = 0,1	m (chosen)

W ₁ = 800 · 1,2 ² · 0,5	=	576 Nm
W ₂ = 1000 · 4 · 2,5 · 0,1 / 1,2	=	834 Nm
W ₃ = 576 + 834	=	1 410 Nm
W ₄ = 1410 · 100	=	141 000 Nm/h
me = 2 · 1410 / 1,2 ²	=	1 958 kg

Chosen from capacity chart :
Model **MC 64100 M-2 self-compensating**

Do not forget to include the rotational energy of motor, coupling and gearbox into calculation for W₂.

4 Mass on driven rollers

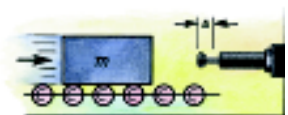

Formulae

$$W_1 = m \cdot v^2 \cdot 0,5$$

$$W_2 = m \cdot \mu \cdot g \cdot s$$

$$W_3 = W_1 + W_2$$

$$W_4 = W_3 \cdot x$$

$$V_D = v$$

$$me = \frac{2 \cdot W_3}{V_D^2}$$

Example

m = 250	kg
v = 1,5	m/s
x = 180	/hr
(steel/steel)	μ = 0,2
s = 0,05	m (chosen)

W ₁ = 250 · 1,5 ² · 0,5	=	281 Nm
W ₂ = 250 · 0,2 · 9,81 · 0,05	=	25 Nm
W ₃ = 281 + 25	=	306 Nm
W ₄ = 306 · 180	=	55 080 Nm/h
me = 2 · 306 / 1,5 ²	=	272 kg

Chosen from capacity chart :
Model **MC 4550 M-2 self-compensating**

5 Swinging mass with propelling force

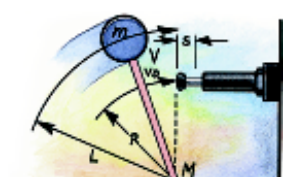

Formulae

$$W_1 = m \cdot v^2 \cdot 0,5 = 0,5 \cdot J \cdot \omega^2$$

$$W_2 = \frac{M \cdot s}{R}$$

$$W_3 = W_1 + W_2$$

$$W_4 = W_3 \cdot x$$

$$V_D = \frac{v \cdot R}{L} = \omega \cdot R$$

$$me = \frac{2 \cdot W_3}{V_D^2}$$

Example

m = 20	kg
v = 1	m/s
M = 50	Nm
R = 0,5	m
L = 0,8	m
x = 1500	/hr
s = 0,0125	m (chosen)

Check the side load angle, tan α = s/R (see example 6.2)

W ₁ = 20 · 1 ² · 0,5	=	10 Nm
W ₂ = 50 · 0,0125 / 0,5	=	1,3 Nm
W ₃ = 10 + 1,3	=	11,3 Nm
W ₄ = 11,3 · 1500	=	16 950 Nm/h
V _D = 1 · 0,5 / 0,8	=	0,63 m/s
me = 2 · 11,3 / 0,63 ²	=	57 kg

Chosen from capacity chart :
Model **MC 150 MH self-compensating**

Formulae and calculation examples

6 Free falling mass

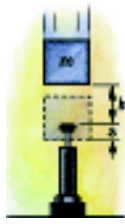

Formulae

$$\begin{aligned} W_1 &= m \cdot g \cdot h \\ W_2 &= m \cdot g \cdot s \\ W_3 &= W_1 + W_2 \\ W_4 &= W_3 \cdot x \\ v_D &= \sqrt{2 \cdot g \cdot h} \\ me &= \frac{2 \cdot W_3}{v_D^2} \end{aligned}$$

Example

m = 30	kg	$W_1 = 30 \cdot 0,5 \cdot 9,81$	=	147	Nm
h = 0,5	m	$W_2 = 30 \cdot 9,81 \cdot 0,05$	=	15	Nm
x = 400	/hr	$W_3 = 147 + 15$	=	162	Nm
s = 0,05	m (choisie)	$W_4 = 162 \cdot 400$	=	64 800	Nm/h

$$\begin{aligned} v_D &= \sqrt{2 \cdot 9,81 \cdot 0,5} = 3,13 \text{ m/s} \\ me &= \frac{2 \cdot 162}{3,13^2} = \mathbf{33 \text{ kg}} \end{aligned}$$

Chosen from capacity chart :
Model **MC 3350 M-1 self-compensating**

6.1 Mass rolling / sliding down incline

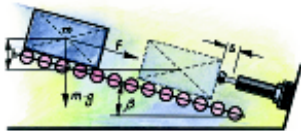

Formulae

$$\begin{aligned} W_1 &= m \cdot g \cdot h = m \cdot v_D^2 \cdot 0,5 \\ W_2 &= m \cdot g \cdot \sin\beta \cdot s \\ W_3 &= W_1 + W_2 \\ W_4 &= W_3 \cdot x \\ v_D &= \sqrt{2 \cdot g \cdot h} \\ me &= \frac{2 \cdot W_3}{v_D^2} \\ W_2 &= (F - m \cdot g \cdot \sin\beta) \cdot s \\ W_2 &= (F + m \cdot g \cdot \sin\beta) \cdot s \end{aligned}$$

6.2 Mass free falling about a pivot point

Check side load angle from shock absorber axis

Calculation as per example 6.1 excepted $W_2 = 0$

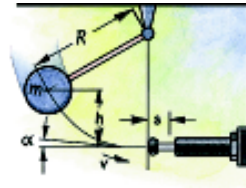

$$\tan \alpha = \frac{s}{R}$$

6.1 a propelling force up incline

6.1 b propelling force down incline

7 Rotary index table with propelling torque

Note : Mass with uniform weight

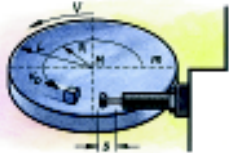

Formulae

$$\begin{aligned} W_1 &= m \cdot v^2 \cdot 0,25 = 0,5 \cdot J \cdot \omega^2 \\ W_2 &= \frac{M \cdot s}{R} \\ W_3 &= W_1 + W_2 \\ W_4 &= W_3 \cdot x \\ v_D &= \frac{v \cdot R}{L} = v \cdot R \\ me &= \frac{2 \cdot W_3}{v_D^2} \end{aligned}$$

Example

m = 1000	kg	$W_1 = 1000 \cdot 1,1^2 \cdot 0,25$	=	303	Nm
v = 1,1	m/s	$W_2 = 1000 \cdot 0,05 / 0,8$	=	63	Nm
M = 1000	Nm	$W_3 = 303 + 63$	=	366	Nm
s = 0,05	m (chosen)	$W_4 = 366 \cdot 100$	=	36 600	Nm/h
L = 1,25	m	$v_D = 1,1 \cdot 0,8 / 1,25$	=	0,7	m/s
R = 0,8	m	$me = 2 \cdot 366 / 0,7^2$	=	1 494	kg
x = 100	/hr	Chosen from capacity chart : Model MC 4550 M-3 self-compensating			

Check side load angle, $\tan \alpha = s/R$ (see example 6.2)

8 Swinging arm with propelling torque

Note : Mass with uniform weight



Formulae

$$\begin{aligned} W_1 &= m \cdot v^2 \cdot 0,18 = 0,5 \cdot J \cdot \omega^2 \\ W_2 &= \frac{M \cdot s}{R} \\ W_3 &= W_1 + W_2 \\ W_4 &= W_3 \cdot x \\ v_D &= \frac{v \cdot R}{L} = \omega \cdot R \\ me &= \frac{2 \cdot W_3}{v_D^2} \end{aligned}$$

Example

J = 56	kgm ²	$W_1 = 0,5 \cdot 56 \cdot 1^2$	=	28	Nm
$\omega = 1$	rad/s	$W_2 = 300 \cdot 0,025 / 0,8$	=	9	Nm
M = 300	Nm	$W_3 = 28 + 9$	=	37	Nm
s = 0,025	m (chosen)	$W_4 = 37 \cdot 1200$	=	44 400	Nm/h
L = 1,5	m	$v_D = 1 \cdot 0,8$	=	0,8	m/s
R = 0,8	m	$me = 2 \cdot 37 / 0,8^2$	=	116	kg
x = 1200	/hr	Chosen from capacity chart : Model MC 600 M self-compensating			

Check side load angle, $\tan \alpha = s/R$ (see example 6.2)

9 Swinging arm with propelling force

Note : Mass with uniform weight

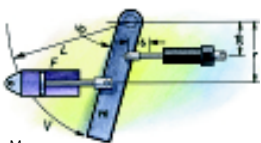

Formulae

$$\begin{aligned} W_1 &= m \cdot v^2 \cdot 0,18 = 0,5 \cdot J \cdot \omega^2 \\ W_2 &= \frac{F \cdot r \cdot s}{R} = \frac{M \cdot s}{R} \\ W_3 &= W_1 + W_2 \\ W_4 &= W_3 \cdot x \\ v_D &= \frac{v \cdot R}{L} = \omega \cdot R \\ me &= \frac{2 \cdot W_3}{v_D^2} \end{aligned}$$

Example

m = 100	kg	$W_1 = 100 \cdot 1,5^2 \cdot 0,18$	=	40,5	Nm
v = 1,5	m/s	$W_2 = 3000 \cdot 0,6 \cdot 0,025 / 0,8$	=	56,5	Nm
F = 3000	N	$W_3 = 40,5 + 56,5$	=	97	Nm
M = 1800	Nm	$W_4 = 97 \cdot 100$	=	9700	Nm/h
s = 0,025	m (chosen)	$v_D = 1,5 \cdot 0,8 / 1,2$	=	1	m/s
r = 0,6	m	$me = 2 \cdot 97 / 1^2$	=	194	kg
R = 0,8	m	Chosen from capacity chart : Modele MC 3325 M-3 self-compensating			
L = 1,2	m				
x = 100	/hr				

10 Mass lowered at controlled speed

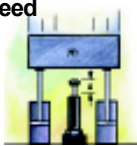

Formulae

$$\begin{aligned} W_1 &= m \cdot v^2 \cdot 0,5 \\ W_2 &= m \cdot g \cdot s \\ W_3 &= W_1 + W_2 \\ W_4 &= W_3 \cdot x \\ v_D &= v \\ me &= \frac{2 \cdot W_3}{v_D^2} \end{aligned}$$

Example

m = 1000	kg	$W_1 = 1000 \cdot 1,5^2 \cdot 0,5$	=	1125	Nm
v = 1,5	m/s	$W_2 = 1000 \cdot 9,81 \cdot 0,1$	=	981	Nm
s = 0,1	m (chosen)	$W_3 = 1125 + 981$	=	2106	Nm
x = 60	/hr	$W_4 = 2106 \cdot 60$	=	126 360	Nm/h
		$me = 2 \cdot 2106 / 1,5^2$	=	1872	kg

Chosen from capacity chart :
Modele **MC 64100 M-2 self-compensating**

Reaction force Q (N)

$$Q = \frac{1,5 \cdot W_3}{s}$$

Stopping time (s)

$$t = \frac{2,6 \cdot s}{v_D}$$

Deceleration (m/s²)

$$a = \frac{0,75 \cdot v_D^2}{s}$$

Approximate values assuming correct adjustment. Add safety margin if necessary.

Effective weight

It is an imaginary factor, given in kg, which allow to check the efficiency of a shock absorber taking into account of :

- the total of kinetic energy and propelling force (Nm)
- the impact velocity (m/s)

For each shock absorber a range of effective weight is shown in the capacity chart. If the effective weight **me** is within the indicated range of the unit, the deceleration will be *linear and so of good quality*.

Examples:

Mass without propelling force

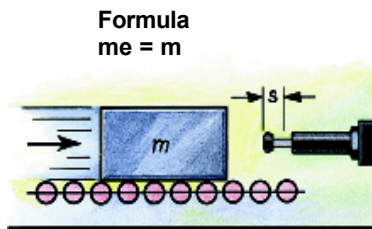

Figure A

Example:

$$m = 100 \text{ kg}$$

$$V_D = v = 2 \text{ m/s}$$

$$W_1 = W_3 = 200 \text{ Nm}$$

$$me = \frac{2 \cdot 200}{4} = 100 \text{ kg}$$

$$me = m$$

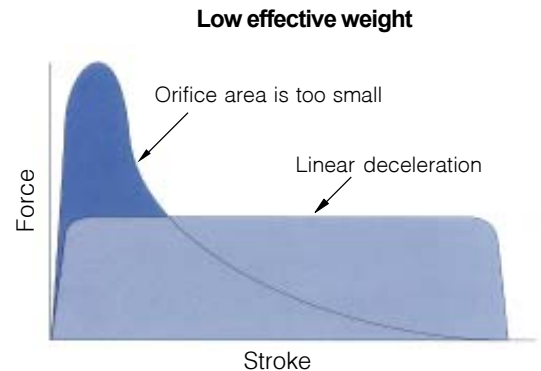

Figure B

A 100 kg weight travelling at 2 m/s has a 200 Nm of kinetic energy (fig A). On this basis alone, a MC 3350 M-3 model would be selected. However, the effective weight for this application (100 kg) is below the effective weight range of the standard of this unit (210 to 840 kg). The result is a high on-set force at the start of the stroke due to a low effective weight range of the load (fig. B). For a good deceleration, the best solution is to chose the unit **MC 3350 M-2**, which matches perfectly the application.

Mass with propelling force

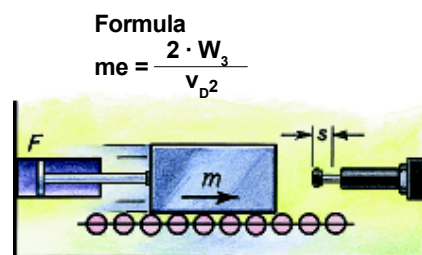

Figure C

Example:

$$m = 100 \text{ kg}$$

$$F = 2000 \text{ N}$$

$$V_D = v = 2 \text{ m/s}$$

$$s = 0,1 \text{ m}$$

$$W_1 = 200 \text{ Nm}$$

$$W_2 = 200 \text{ Nm}$$

$$W_3 = 400 \text{ Nm}$$

$$me = \frac{2 \cdot 400}{4} = 200 \text{ kg}$$

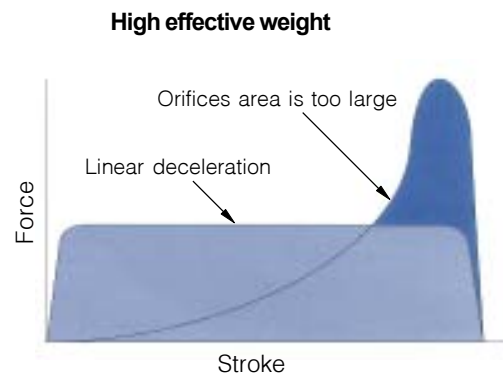

Figure D

A 100 kg weight travelling at 2 m/s, propelled by a 2000 N of propelling force has a 400 Nm of energy (fig C). A MC 4550 M-1 would be selected in that case. However, the effective weight is 200 kg above the effective weight range of this unit. The result is a high set-down force at the end of stroke (fig. D). In that case the best solution is to use a larger shock absorber. The **MC 4550 M-2** unit matches perfectly this application.

Selection:

Determine first your application before selecting a Parker shock absorber. Use the formulae from examples for calculating the energy per cycle and per hour. Determine the effective weight then select the shock absorber which can handle your application.

Capacity chart

Part No	Stroke	Max. energy		Effective weight		Impact velocity (m/s)	Return force		Return time (s)	Max. side load angle (°)	Weight (kg)
		Per cycle	Per hour	Mini.	Maxi.		Mini.	Maxi.			
		W3	W4	me							
MC 9 M1-B	5	1,0	2000	0,6	3,2	from 0,15 to 1,8	1,38	3,78	0,3	2	0,005
MC 9 M2-B	5	1,0	2000	0,8	4,1	from 0,15 to 1,8	1,38	3,78	0,3	2	0,005
MC 10 ML-B	5	0,5	4000	0,3	2,7	from 0,15 to 5	2	4	0,6	3	0,01
MC 10 MH-B	5	0,8	4000	0,7	5	from 0,15 to 5	2	4	0,6	3	0,01
MC 25 ML	6,6	2,8	22500	0,7	2,2	from 0,15 to 5	3	6	0,3	2	0,02
MC 25 M	6,6	2,8	22500	1,8	5,4	from 0,15 to 5	3	6	0,3	2	0,02
MC 25 MH	6,6	2,8	22500	4,6	13,6	from 0,15 to 5	3	6	0,3	2	0,02
MC 75 M-1	10	9	28200	0,3	1,1	from 0,15 to 5	4	9	0,3	2	0,03
MC 75 M-2	10	9	28200	0,9	4,8	from 0,15 to 5	4	9	0,3	2	0,03
MC 75 M-3	10	9	28200	2,7	36,2	from 0,15 to 5	4	9	0,3	2	0,03
MC 150 M	12,5	17	34000	0,9	10	from 0,08 to 6	3	5	0,4	4	0,06
MC 150 MH	12,5	17	34000	8,6	86	from 0,08 to 6	3	5	0,4	4	0,06
MC 150 MH2	12,5	17	34000	70	200	from 0,08 to 6	3	5	0,4	4	0,06
MC 225 M	12,5	25	45000	2,3	25	from 0,08 to 6	4	6	0,3	4	0,15
MC 225 MH	12,5	25	45000	23	230	from 0,08 to 6	4	6	0,3	4	0,15
MC 225 MH2	12,5	25	45000	180	910	from 0,08 to 6	4	6	0,3	4	0,15
MC 600 M	25,4	68	68000	9	136	from 0,08 to 6	5	9	0,6	2	0,26
MC 600 MH	25,4	68	68000	113	1130	from 0,08 to 6	5	9	0,6	2	0,26
MC 600 MH2	25,4	68	68000	400	2300	from 0,08 to 6	5	9	0,6	2	0,26

Part No	Stroke (mm)	Max. energy (Nm)		Effective weight (kg)				Impact Velocity (m/s)	Return Force (N)		Return Time (s)	Max.Side load angle (°)	Weight (kg)
		Per cycle	Per hour	Soft contact	Self compensating	Mini.	Maxi.		Mini.	Maxi.			
		W3	W4	me									
				Mini.	Maxi.	Mini.	Maxi.						
SC 925 M-1	40	110	90000	22	72	14	90	0,15 to 3,7	11	32	0,40	5	0,39
SC 925 M-2	40	110	90000	59	208	40	272	0,15 to 3,7	11	32	0,40	5	0,39
SC 925 M-3	40	110	90000	181	612	113	726	0,15 to 3,7	11	32	0,40	5	0,39

Capacity chart

Part No	Stroke (mm)	Max. Energy		Effective weight		Impact Velocity (m/s)	Return Force		Return Time (s)	Max.Side load angle (°)	Weight (kg)
		(Nm)		(kg)			(N)				
		Per cycle	Per hour	Mini.	Maxi.		Mini.	Maxi.			
		W3	W4	me							
MC 3325 M-1	25	155	75000	9	40	from 0,15 to 5	45	90	0,03	4	0,45
MC 3325 M-2	25	155	75000	30	120	from 0,15 to 5	45	90	0,03	4	0,45
MC 3325 M-3	25	155	75000	100	420	from 0,15 to 5	45	90	0,03	4	0,45
MC 3350 M-1	50	310	85000	18	70	from 0,15 to 5	45	135	0,06	3	0,54
MC 3350 M-2	50	310	85000	60	250	from 0,15 to 5	45	135	0,06	3	0,54
MC 3350 M-3	50	310	85000	210	840	from 0,15 to 5	45	135	0,06	3	0,54
MC 4525 M-1	25	340	107000	20	90	from 0,15 to 5	70	100	0,03	4	1,13
MC 4525 M-2	25	340	107000	80	310	from 0,15 to 5	70	100	0,03	4	1,13
MC 4525 M-3	25	340	107000	260	1050	from 0,15 to 5	70	100	0,03	4	1,13
MC 4550 M-1	50	680	112000	45	180	from 0,15 to 5	70	145	0,08	3	1,36
MC 4550 M-2	50	680	112000	150	620	from 0,15 to 5	70	145	0,08	3	1,36
MC 4550 M-3	50	680	112000	520	2090	from 0,15 to 5	70	145	0,08	3	1,36
MC 4575 M-1	75	1020	146000	70	270	from 0,15 to 5	50	180	0,11	2	1,59
MC 4575 M-2	75	1020	146000	230	930	from 0,15 to 5	50	180	0,11	2	1,59
MC 4575 M-3	75	1020	146000	790	3140	from 0,15 to 5	50	180	0,11	2	1,59
MC 6450 M-1	50	1700	146000	140	540	from 0,15 to 5	90	155	0,12	4	2,90
MC 6450 M-2	50	1700	146000	460	1850	from 0,15 to 5	90	155	0,12	4	2,90
MC 6450 M-3	50	1700	146000	1600	6300	from 0,15 to 5	90	155	0,12	4	2,90
MC 64100 M-1	100	3400	192000	270	1100	from 0,15 to 5	105	270	0,34	3	3,70
MC 64100 M-2	100	3400	192000	930	3700	from 0,15 to 5	105	270	0,34	3	3,70
MC 64100 M-3	100	3400	192000	3150	12600	from 0,15 to 5	105	270	0,34	3	3,70
MC 64150 M-1	150	5100	248000	410	1640	from 0,15 to 5	75	365	0,48	2	5,10
MC 64150 M-2	150	5100	248000	1390	5600	from 0,15 to 5	75	365	0,48	2	5,10
MC 64150 M-3	150	5100	248000	4700	18800	from 0,15 to 5	75	365	0,48	2	5,10

General features

Serie MC 9 to MC 600

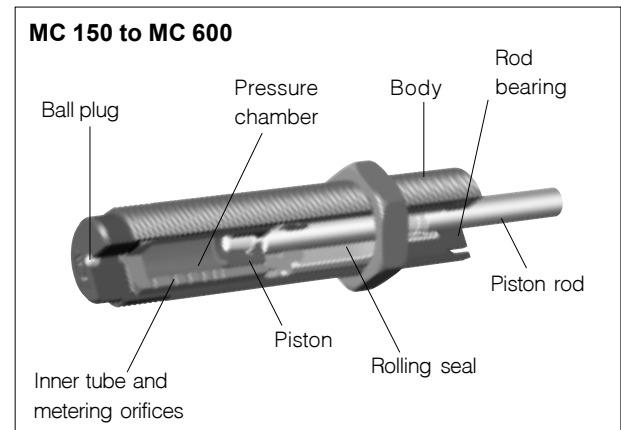
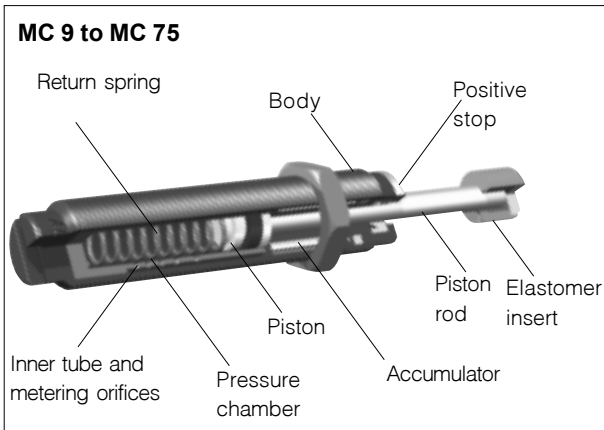

Serie	MC 9	MC 10	MC 25	MC 75	MC 150	MC 225	MC 600
Thread (mm)	M6 x 0,5	M8 x 1	M10 x 1	M12 x 1	M14 x 1,5	M20 x 1,5	M25 x 1,5
Type		Self-compensating			Self-compensating		
Mechanical stop		Built-in end of stroke			A mechanical stop must be provided*		
Impact velocity (m/s)	0,15 to 1,8	0,15 to 5			0,08 to 6		
Stroke (mm)	5	5	6,6	10	12,5	12,5	25,4
Max. capacity per cycle (Nm)	1,0	0,8	2,8	9	17	25	68
Temperature (°C)		0 to 65			0 à 65		

* A mechanical stop must be provided at about 1 mm before the shock absorber end of stroke.

For MC 150, 225 and 600 series do not twist or turn the piston rod.

Serie SC 925

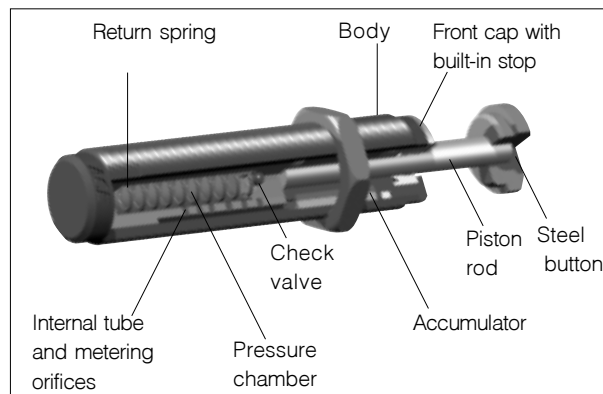

Serie	SC 925
Thread (mm)	M25 x 1,5
Type	Self-compensating/Soft contact
Mechanical stop	Built-in end of stroke
Impact velocity (m/s)	0,15 to 3,7
Stroke (mm)	40
Max. capacity per cycle (Nm)	110
Temperature (°C)	-12 to 90

Dimensions (mm)

Serie MC 9 M to MC 75 M

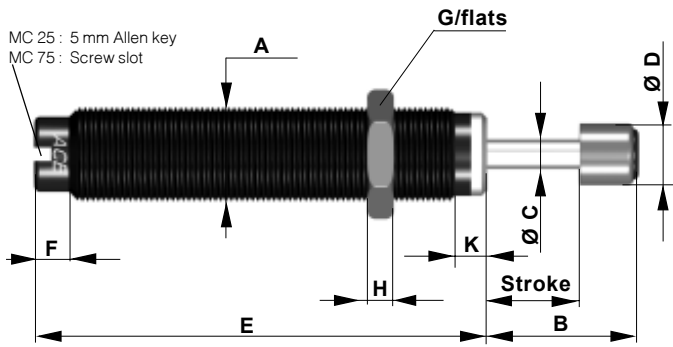

Serie MC 150 M to MC 600 M

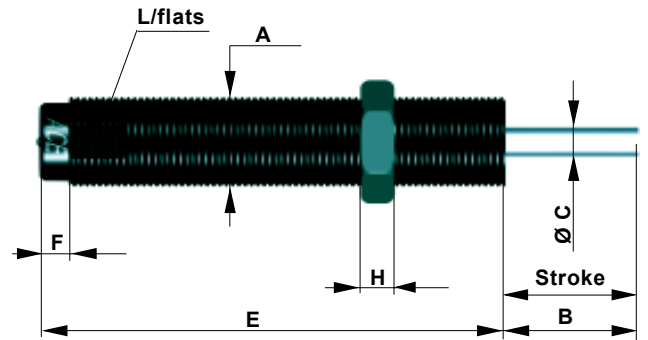

Part No	Stroke (mm)	A	B	C	D	E	F	G	H	K	L
MC 9 M-1-B	5	M6 x 0,5	10	2	4,8	26	2,5	8	2,5	1	-
MC 9 M-2-B	5	M6 x 0,5	10	2	4,8	26	2,5	8	2,5	1	-
MC 10 ML-B	5	M8 x 1	10	2	6,4	28,5	5	11	3	2	-
MC 10 MH-B	5	M8 x 1	10	2	6,4	28,5	5	11	3	2	-
MC 25 ML	6,6	M10 x 1	14,6	3,2	7,6	43,4	5	13	3	5	-
MC 25 M	6,6	M10 x 1	14,6	3,2	7,6	43,4	5	13	3	5	-
MC 25 MH	6,6	M10 x 1	14,6	3,2	7,6	43,4	5	13	3	5	-
MC 75 M-1	10	M12 x 1	18	3,2	7,6	52	5	14	4	3	-
MC 75 M-2	10	M12 x 1	18	3,2	7,6	52	5	14	4	3	-
MC 75 M-3	10	M12 x 1	18	3,2	7,6	52	5	14	4	3	-
MC 150 M	12,5	M14 x 1,5	17,5	4,8	-	70	8,5	17	5	-	12
MC 150 MH	12,5	M14 x 1,5	17,5	4,8	-	70	8,5	17	5	-	12
MC 150 MH2	12,5	M14 x 1,5	17,5	4,8	-	70	8,5	17	5	-	12
MC 225 M	12,5	M20 x 1,5	17,5	6,3	-	80	8,5	24	6	-	18
MC 225 MH	12,5	M20 x 1,5	17,5	6,3	-	80	8,5	24	6	-	18
MC 225 MH2	12,5	M20 x 1,5	17,5	6,3	-	80	8,5	24	6	-	18
MC 600 M	25,4	M25 x 1,5	32	8	-	111	9	30	8	-	23
MC 600 MH	25,4	M25 x 1,5	32	8	-	111	9	30	8	-	23
MC 600 MH2	25,4	M25 x 1,5	32	8	-	111	9	30	8	-	23

Serie SC 925

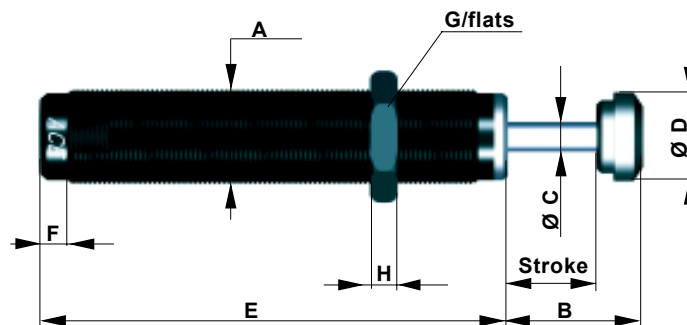

Part No	Stroke (mm)	A	B	C	D	E	F	G	H
SC 925 M-1	40	M25 x 1,5	51	6,3	23	138	7	30	8
SC 925 M-2	40	M25 x 1,5	51	6,3	23	138	7	30	8
SC 925 M-3	40	M25 x 1,5	51	6,3	23	138	7	30	8

Accessories

Stop collar

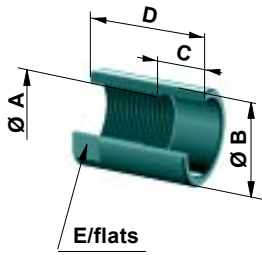

Part No	Used with serie	ØA	ØB	C	D	E
AH6	MC 9 M	M 6 x 0,5	8	6	12	-
AH8	MC 10 M	M 8 x 1	11	6	12	-
AH10	MC 25 M	M 10 x 1	14	10	20	-
AH12	MC 75 M	M 12 x 1	16	10	20	-
AH14	MC 150 M	M 14 x 1,5	18	12	20	15
AH20	MC 225 M	M 20 x 1,5	25	12	25	22
AH25	MC 600 M	M 25 x 1,5	32	16	32	27
	SC 925 M	M 25 x 1,5	32	16	32	27

Clamp

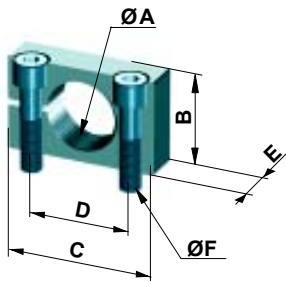

Part No	Used with serie	ØA	B	C	D	E	ØF
MB6	MC 9 M	M 6 x 0,5	10	20	12	8	M3
MB8	MC 10 M	M 8 x 1	12	25	16	10	M4
MB10	MC 25 M	M 10 x 1	14	25	16	10	M4
MB12	MC 75 M	M 12 x 1	16	32	20	12	M5
MB14	MC 150 M	M 14 x 1,5	20	32	20	12	M5
MB20	MC 225 M	M 20 x 1,5	25	40	28	20	M6
MB25	MC 600 M	M 25 x 1,5	32	46	34	25	M6
	SC 925 M	M 25 x 1,5	32	46	34	25	M6

Side load adaptor

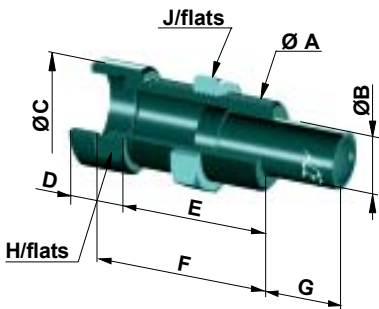

Part No	Used with serie	ØA	ØB	ØC	D	E	ØF	G	H	J
BV8	MC 10 M	M 8 x 1	4	11	10	10	12	5	9	11
BV10	MC 25 M	M 10 x 1	6	13	11	12	15	6,5	11	13
BV12	MC 75 M	M 12 x 1	7	15	12	18	22	10	14	14
BV14	MC 150 M	M 14 x 1,5	9	18	12	20	24	12,5	16	17
BV20	MC 225 M	M 20 x 1,5	12	24	14	20	24	12,5	22	24
BV25	MC 600 M	M 25 x 1,5	16	30	16	38	44	25	27	30
	SC 925 M	M 25 x 1,5	16	30	16	38	44	25	27	30

Rectangular flange

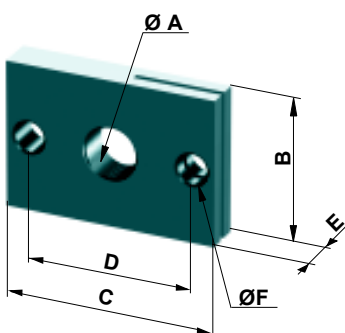

Part No	Used with serie	ØA	B	C	D	E	ØF
RF6	MC 9 M	M 6 x 0,5	10	20	14	5	3,4
RF8	MC 10 M	M 8 x 1	14	25	18	6	4,5
RF10	MC 25 M	M 10 x 1	14	28	20	6	4,5
RF12	MC 75 M	M 12 x 1	20	32	24	6	5,5
RF14	MC 150 M	M 14 x 1,5	20	34	26	6	5,5
RF20	MC 225 M	M 20 x 1,5	32	46	36	8	6,5
RF25	MC 600 M	M 25 x 1,5	32	52	42	8	6,5
	SC 925 M	M 25 x 1,5	32	52	42	8	6,5

Lock nut

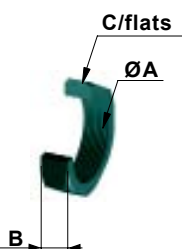

Part No	Used with serie	A	B	C
KM6	MC 9 M	M 6 x 0,5	2,5	8
KM8	MC 10 M	M 8 x 1	3	11
KM10	MC 25 M	M 10 x 1	3	13
KM12	MC 75 M	M 12 x 1	4	14
KM14	MC 150 M	M 14 x 1,5	5	17
KM20	MC 225 M	M 20 x 1,5	6	24
KM25	MC 600 M	M 25 x 1,5	8	30
	SC 925 M	M 25 x 1,5	8	30

General features

Serie MC 33 to MC 64

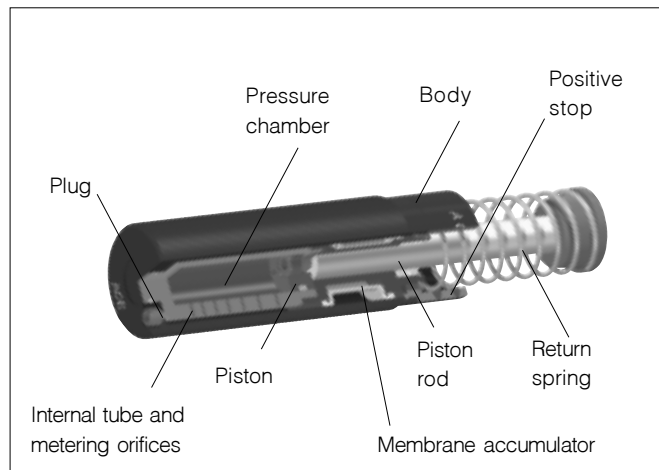

Serie	MC 3325 M	MC 3350 M	MC 4525 M	MC 4550 M	MC 4575 M	MC 6450 M	MC 64100 M	MC 64150 M
Thread (mm)	M33 x 1,5	M33 x 1,5	M45 x 1,5	M45 x 1,5	M45 x 1,5	M64 x 2	M64 x 2	M64 x 2
Type	Self-compensating							
Mechanical stop	Built-in end of stroke							
Impact velocity (m/s)	0,15 to 5							
Stroke (mm)	25	50	25	20	75	50	100	150
Max. capacity per cycle (Nm)	155	310	340	680	1020	1700	3400	5100
Temperature (°C)	- 12 to 70							

Dimensions (mm)

Serie MC 33 to MC 64

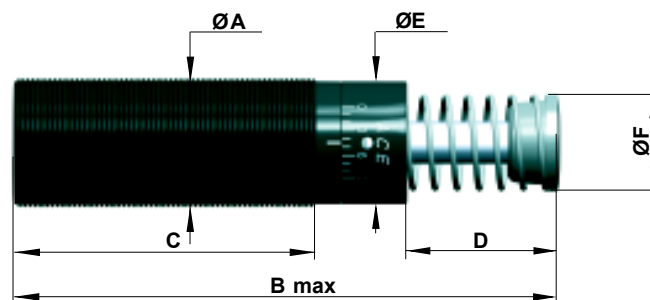

For the 3 ranges of effective weight

Part No	Stroke (mm)	A	B	C	D	E	F
MC 3325 M	25	M33 x 1,5	138	83	23	30	25
MC 3350 M	50	M33 x 1,5	189	108	48,5	30	25
MC 4525 M	25	M45 x 1,5	145	95	23	42	35
MC 4550 M	50	M45 x 1,5	195	120	48,5	42	35
MC 4575 M	75	M45 x 1,5	246	145	74	42	35
MC 6450 M	50	M64 x 2	225	140	48,5	60	48
MC 64100 M	100	M64 x 2	326	191	99,5	60	48
MC 64150 M	150	M64 x 2	450	241	150	60	48

Accessories

Locking Ring

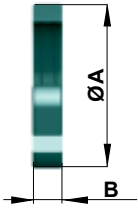

Part No	Used with serie	ØA	B
NM33	MC 3325 M & MC 3350 M	40	6
NM45	MC 4525 M & MC 4550 M & MC 4575 M	57	10
NM64	MC 6450 M & MC 64100 M & MC 64150 M	76	10

Nylon Button

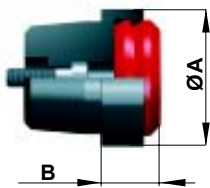

Part No	Used with serie	ØA	B
PP33	MC 3325 M & MC 3350 M	29	12
PP45	MC 4525 M & MC 4550 M & MC 4575 M	42	18
PP64	MC 6450 M & MC 64100 M & MC 64150 M	60	18

Square Flange

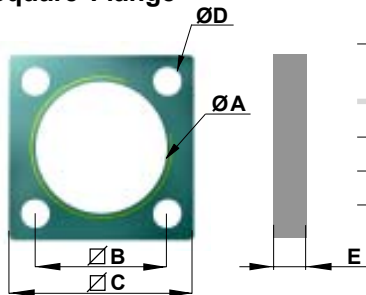

Part No	Used with serie	ØA	ØD	∠B	∠C	E
QF33	MC 3325 M & MC 3350 M	M33 x 1,5	6,6	32	44	12
QF45	MC 4525 M & MC 4550 M & MC 4575 M	M45 x 1,5	9	42	56	15
QF64	MC 6450 M & MC 64100 M & MC 64150 M	M64 x 2	11	58	80	20

Side foot Mounting Kit

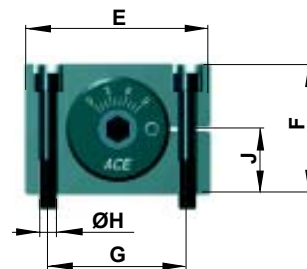
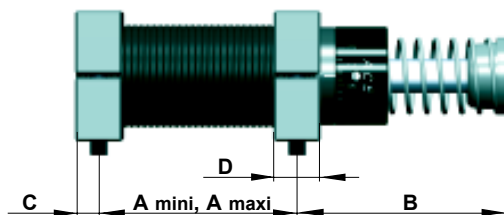

- S33** = 2 flanges + 4 screws M6 x40
- S45** = 2 flanges + 4 screws M8 x50
- S64** = 2 flanges + 4 screws M10 x80

Tightening torque
S33 = 11 Nm **S45** = 27 Nm **S64** = 50 Nm

Removing torque
S33 > 90 Nm **S45** > 350 Nm **S64** > 350 Nm

Part No	Used with serie	A mini	A maxi	B	C	D	E	F	G	ØH	J
S33	MC 3325 M	25	60	68	10	20	56	40	42	6,6	20
S33	MC 3350 M	32	86	93	10	20	56	40	42	6,6	20
S45	MC 4525 M	32	66	66	12,5	25	80	56	60	9	28
S45	MC 4550 M	40	92	91	12,5	25	80	56	60	9	28
S45	MC 4575 M	50	118	116	12,5	25	80	56	60	9	28
S64	MC 6450 M	50	112	100	12,5	25	100	80	78	11	40
S64	MC 64100 M	64	162	152	12,5	25	100	80	78	11	40
S64	MC 64150 M	80	212	226	12,5	25	100	80	78	11	40

Clevis Mounting Kit

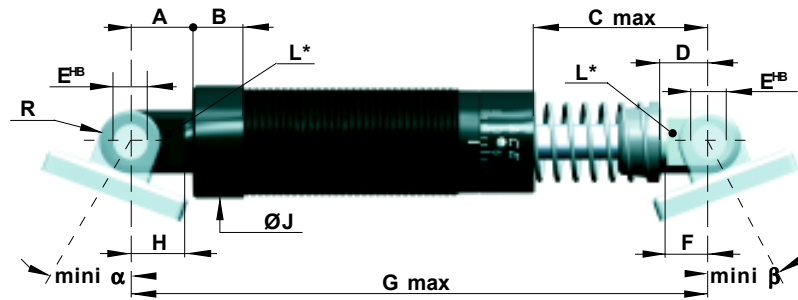

S33 =
S45 = 2 clevis shipped fitted onto shock absorber
S64 =

Part No	Used with serie	A	B	Cmax	D	E ^B	F	G max	H	ØJ	L*	R	mini α	mini β
C33	MC 3325 M	14	14	39	14	10	13	168	13	38	13	10	20°	0°
C33	MC 3350 M	14	14	64	14	10	13	218	13	38	13	10	20°	0°
C45	MC 4525 M	28	20	43	18	16	17	200	20	53	20	14	15°	15°
C45	MC 4550 M	28	20	68	18	13	17	250	20	53	20	14	15°	15°
C45	MC 4575 M	28	20	93	18	13	17	300	20	53	20	14	15°	15°
C64	MC 6450 M	35	25	85	35	20	30	310	30	74	24	20	20°	10°
C64	MC 64100 M	35	25	136	35	20	30	410	30	74	24	20	20°	10°
C64	MC 64150 M	35	25	187	35	20	30	530	30	74	24	20	20°	10°

L* indicates the width of front and rear clevis

Female Fitting

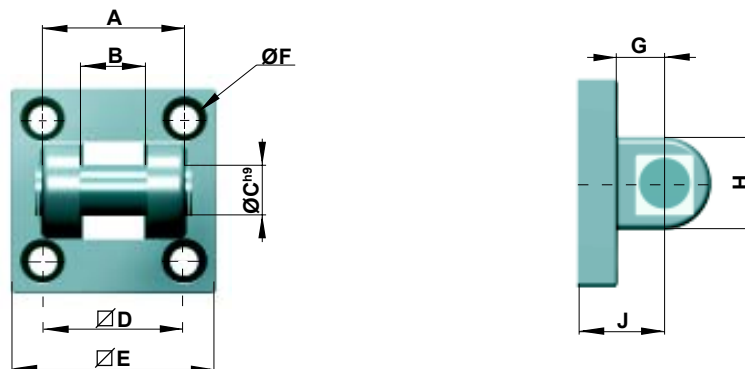

Supplied with 4 mounting screws

Part No	Used with serie	A	B	ØC ^{h9}	ØD	ØE	ØF	G	H	J
P1C-4KMC	MC 3325 M , MC 3350 M	34	14	10	32	48	7	13	23	22
P1C-4MMC	MC 4525 M, MC 4550 M, MC 4575 M	45	21	16	46	65	9	15	29	27
P1C-4PMC	MC 6450 M, MC 64100 M, MC 64150 M	65	25	20	72	95	11	22	45	36