



Short Build Pneumatic Cylinders

P1M Series

*Catalogue PDE2562TCUK-ul
December 2006*



Features	Air cylinder	Hydraulic cylinder	Electro mechanical actuators
Overload safe	***	***	*
Easy to limit force	***	***	*
Easy to vary speed	***	***	*
Speed	***	**	**
Reliability	***	***	***
Robustness	***	***	*
Installation cost	***	*	**
Ease of service	***	**	*
Safety in damp environments	***	***	*
Safety in explosive atmospheres	***	***	*
Safety risk with electrical installations	***	***	*
Risk of oil leak	***	*	***
Clean, hygienic	***	**	*
Standardised measurements	***	***	*
Service life	***	***	*
Hydraulic system required	***	*	***
Weight	***	**	**
Purchase price	***	**	*
Power density	**	***	*
Noise level during operation	**	***	**
High force for size	**	***	*
Positioning possibilities	*	***	***
Total energy consumption	*	**	***
Service interval	*	**	***
Compressor capacity required	*	***	***

* = good, **=average, ***=excellent



Important
 Before attempting any external or internal work on the cylinder or any connected components, make sure the cylinder is vented and disconnect the air supply in order to ensure isolation of the air supply.



Note
 All technical data in this catalogue are typical data only.
 Air quality is essential for maximum cylinder service life (see ISO 8573).



WARNING

FAILURE OR IMPROPER SELECTION OR IMPROPER USE OF THE PRODUCTS AND/OR SYSTEMS DESCRIBED HEREIN OR RELATED ITEMS CAN CAUSE DEATH, PERSONAL INJURY AND PROPERTY DAMAGE.

This document and other information from Parker Hannifin Corporation, its subsidiaries and authorized distributors provide product and/or system options for further investigation by users having technical expertise. It is important that you analyze all aspects of your application and review the information concerning the product or system in the current product catalog. Due to the variety of operating conditions and applications for these products or systems, the user, through its own analysis and testing, is solely responsible for making the final selection of the products and systems and assuring that all performance, safety and warning requirements of the application are met. The products described herein, including without limitation, product features, specifications, designs, availability and pricing, are subject to change by Parker Hannifin Corporation and its subsidiaries at any time without notice.

SALE CONDITIONS

The items described in this document are available for sale by Parker Hannifin Corporation, its subsidiaries or its authorized distributors. Any sale contract entered into by Parker will be governed by the provisions stated in Parker's standard terms and conditions of sale (copy available upon request).

Contents	Page
General information	4-5
Cylinder forces	6
Main data: P1M	7
Material specification	7
Cushioning diagram	7
Working medium, air quality	7
Guide for selecting suitable tubing	8
Valve series with respective flows in NI/minute	9
Dimensions,	10-13
Order key.....	14
Standard stroke length in mm	14
Order code standard strokes, double acting	15-16
Order code standard strokes, single acting.....	17
Cylinder mountings	18-25
Sensors	26-28
Sensors for special applications	29-30
Connecting cables with one connector.....	31
Male connectors for connecting cables	31
Ready to use connecting cables with connectors at each end	31
Connection block Valvetronic 110.....	32
Seal kits and Grease for P1M	33

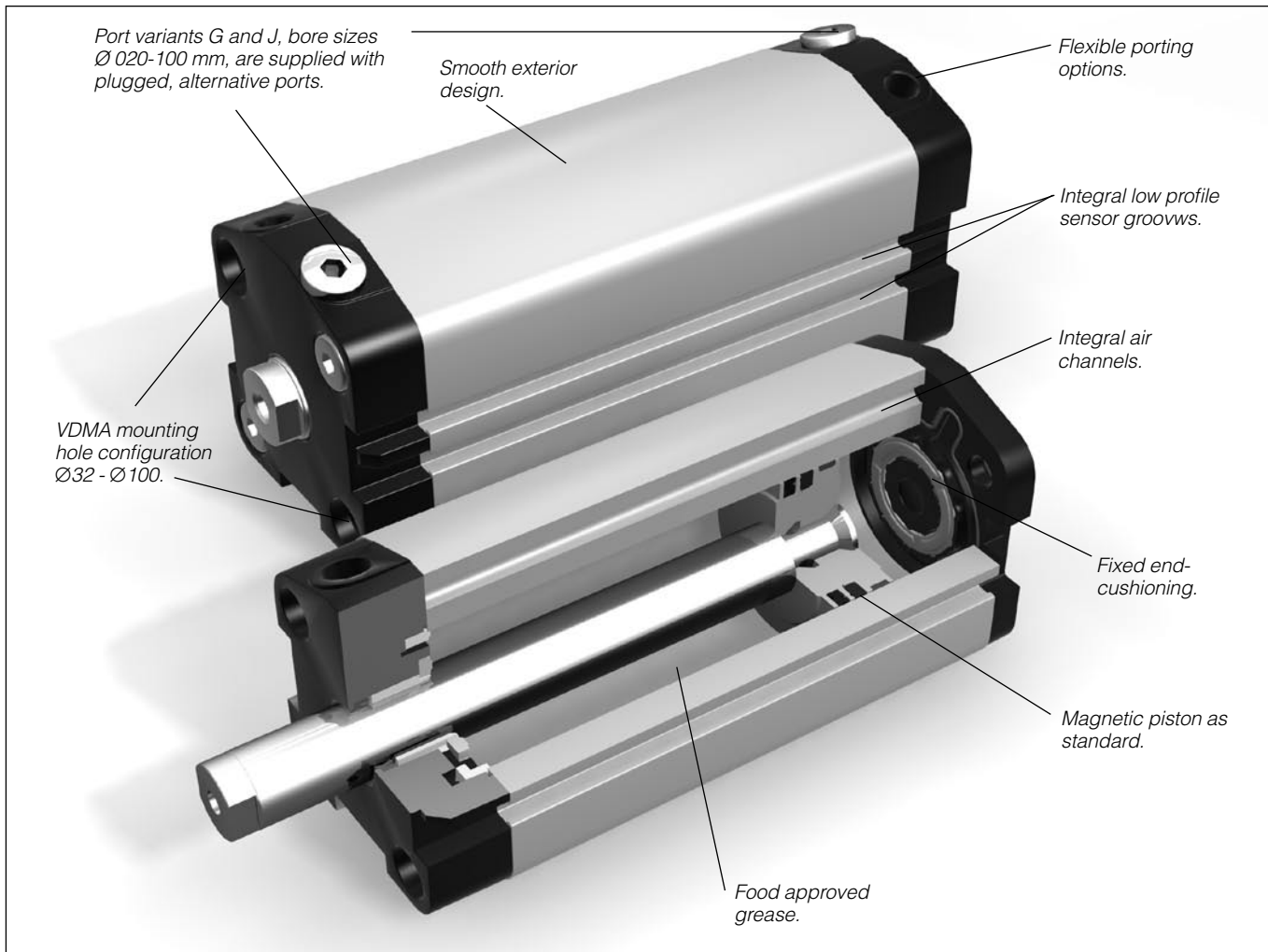

Short Build Cylinders

Parker Pneumatic's versatile range of Short Build Cylinders, with unique porting options, integral sensor grooves and one of the shortest overall lengths on the market is suitable for a wide range of applications.

The range comprises ten cylinder bore sizes, 12 - 100 mm diameter, with stroke lengths from 5 to 500 mm and, as with other Parker cylinders, Short Build Cylinders are factory-lubricated with food grade grease (USDA).

The extremely small overall dimensions have been achieved through an entirely new design. Channels in the body supply air to either end of the cylinder. This means that the connection ports in the front or rear end walls can be configured to suit individual requirements. Port variants G and J, bore sizes Ø 020-100 mm, are also supplied with plugged, alternative ports, which permit a free choice of connections.

The flexible porting option, together with a choice of mounting methods, ensures that this range of cylinders can be used in variety of applications. It is especially suitable for use in applications where space is limited as, for example, in the packaging or electronic industries.

Options

In addition to the basic version with stainless steel piston rod, magnetic piston and fixed end cushioning, the range will include several standard options that provide a wide range of choices.

Options include single acting cylinders, through rod and hollow through rod, male or female threaded rods and high-temperature versions.

Sensors and accessories

The P1M-series incorporates a further unique feature: integral sensor grooves. The grooves are recessed into the barrel, enabling sensors to be quickly and easily fitted without increasing external dimensions. Double grooves allow sensors to be grouped together.

Hole patterns for the mountings, as for all the mounts in the complete range of mountings, comply with the VDMA-standards.

Fixed-cushioning

Bumpers in Polyurethane as standard.

Smooth external design

The end plates have no recesses or other grooves that could collect dirt or liquid. Cleaning is easy and effective.

Flexible port location

The P1M is available with several different port locations. Both ports in the front end wall (H), which gives extremely short installation dimensions, both ports in the rear end wall (J), or one port in the front wall and one in the rear wall (G) as in a conventional cylinder.

Port variants G and J, bore sizes \varnothing 020-100 mm, are also supplied with plugged, alternative ports in the front and rear end walls, which permits a free choice of connections.

Position sensing

All cylinders in standard temperature design are fitted with a magnet for position sensing. Electronic type sensors and reed switches are available. They are supplied with either flying lead or cable plug connector.

Complete range of mountings

A complete range of mounting accessories is available.

Variants

In addition to the basic design, several standard variants of these Short Built Cylinders are available to fulfill more demanding requirements in terms of performance and environmental conditions:

Cylinders with special stroke lengths

Cylinders with extended piston rods

Cylinders with male piston rod thread

Through piston rods

Through hollow piston rods

Single-acting cylinders with spring return, push and pull

Cylinders with axial connections.

High-temperature versions for operation in temperature range from -10 °C to +150 °C (not magnetic pistons, not bumpers)



Double acting, ports in front and rear plate



Double acting, both ports in front plate



Double acting, both ports in rear plate radially



Single acting



Through piston rod



Through hollow piston rod



Male rod end

Cylinder forces, double acting variants

Cyl. bore/ pist. rod mm	Stroke	Piston area cm ²	Max theoretical force in N (bar)									
			1,0	2,0	3,0	4,0	5,0	6,0	7,0	8,0	9,0	10,0
12/6	+	1,1	11	23	34	45	57	68	79	90	102	113
	-	0,8	8	17	25	34	42	51	59	68	76	85
16/8	+	2,0	20	40	60	80	100	120	141	161	181	201
	-	1,5	15	30	45	60	75	90	106	121	136	151
20/10	+	3,1	31	63	94	126	157	188	220	251	283	314
	-	2,3	23	46	69	92	115	138	161	184	207	231
25/10	+	4,9	49	98	147	196	245	295	344	393	442	491
	-	4,1	41	82	124	165	206	247	289	330	371	412
32/12	+	8,0	80	161	241	322	402	483	563	643	724	804
	-	6,9	69	138	207	276	346	415	484	553	622	691
40/16	+	12,6	126	251	377	503	628	754	880	1005	1131	1257
	-	10,6	106	211	317	422	528	633	739	844	950	1056
50/20	+	19,6	196	393	589	785	982	1178	1374	1571	1767	1963
	-	16,5	165	330	495	660	825	990	1155	1319	1484	1649
63/20	+	31,2	312	623	935	1247	1559	1870	2182	2494	2806	3117
	-	28,0	280	561	841	1121	1402	1682	1962	2242	2523	2803
80/25	+	50,3	503	1005	1508	2011	2513	3016	3519	4021	4524	5027
	-	45,4	454	907	1361	1814	2268	2721	3175	3629	4082	4536
100/25	+	78,5	785	1571	2356	3142	3927	4712	5498	6283	7069	7854
	-	73,6	736	1473	2209	2945	3682	4418	5154	5890	6627	7363

+ = Outward stroke
- = Return stroke

Note!

Select a theoretical force 50-100% larger than the force required

Cylinder forces

Indicated cylinder forces are theoretical and should be reduced according to the working conditions.

Cylinder designation	Theoretical cylinder force at 6 bar				Cylinder designation	Theoretical cylinder force at 6 bar			
	expanding stroke		spring retraction			expanding stroke		spring retraction	
	Nmax	Nmin	Nmax	Nmin		Nmax	Nmin	Nmax	Nmin
Single acting, spring return for retract stroke					Single acting, spring return for advanced stroke				
P1M012VR•A••005	59	55	12	8	P1M012VE•A••005	43	36	14	7
P1M012VR•A••010	63	55	12	4	P1M012VE•A••010	45	40	10	5
P1M016VR•A••005	107	102	18	13	P1M016VE•A••005	80	69	22	11
P1M016VR•A••010	111	102	18	9	P1M016VE•A••010	84	75	16	7
P1M020VR•A••005	176	169	17	12	P1M020VE•A••005	129	123	19	13
P1M020VR•A••010	180	169	17	8	P1M020VE•A••010	130	119	23	12
P1M025VR•A••005	276	271	23	18	P1M025VE•A••005	232	224	23	15
P1M025VR•A••010	281	271	23	13	P1M025VE•A••010	233	217	30	14
P1M032VR•A••005	464	453	29	18	P1M032VE•A••005	387	379	35	27
P1M032VR•A••010	469	453	29	13	P1M032VE•A••010	395	379	35	19
P1M040VR•A••005	726	720	34	28	P1M040VE•A••005	587	577	56	46
P1M040VR•A••010	732	720	34	22	P1M040VE•A••010	598	577	56	35
P1M050VR•A••010	1126	1115	63	52	P1M050VE•A••010	951	928	61	38
P1M050VR•A••025	1141	1105	73	37	P1M050VE•A••025	947	901	88	42
P1M063VR•A••010	1818	1807	63	52	P1M063VE•A••010	1643	1625	56	38
P1M063VR•A••025	1833	1797	73	37	P1M063VE•A••025	1639	1593	88	42
P1M080VR•A••010	2910	2888	128	106	P1M080VE•A••010	2593	2525	196	128
P1M080VR•A••025	2942	2888	128	74	P1M080VE•A••025	2621	2531	190	100
P1M100VR•A••010	4606	4548	128	106	P1M100VE•A••010	4289	4221	196	128
P1M100VR•A••025	4638	4548	128	74	P1M100VE•A••025	4317	4227	190	100

Main data: P1M

Cylinder designation	Cylinder bore		Piston rod bore		Piston rod thread		Total mass		Moving mass		Air consumption	Conn. thread
	mm	cm ²	mm	cm ²	(female)	(male)	at 0 mm stroke	addition per 10 mm stroke	at 0 mm stroke	addition per 10 mm stroke		
P1M012	12	1,13	6	0,28	M3	M6	0,060	0,016	0,010	0,002	0,0139 ¹⁾	M5
P1M016	16	2,01	8	0,50	M4	M6	0,090	0,022	0,015	0,004	0,0246 ¹⁾	M5
P1M020	20	3,14	10	0,78	M5	M8	0,150	0,032	0,025	0,006	0,0385 ¹⁾	M5
P1M025	25	4,91	10	0,78	M6	M10x1,25	0,170	0,034	0,030	0,006	0,0633 ¹⁾	M5
P1M032	32	8,0	12	1,1	M6	M10x1,25	0,260	0,044	0,050	0,009	0,1050 ¹⁾	G1/8
P1M040	40	12,6	16	2,0	M6	M12x1,25	0,370	0,060	0,090	0,016	0,1620 ¹⁾	G1/8
P1M050	50	19,6	20	3,1	M8	M16x1,5	0,570	0,085	0,140	0,025	0,2530 ¹⁾	G1/8
P1M063	63	31,2	20	3,1	M8	M16x1,5	0,860	0,098	0,220	0,025	0,4140 ¹⁾	G1/8
P1M080	80	50,3	25	4,9	M10	M20x1,5	1,460	0,146	0,380	0,039	0,6690 ¹⁾	G1/4
P1M100	100	78,5	25	4,9	M12	M20x1,5	2,390	0,155	0,650	0,039	1,0430 ¹⁾	G1/4

1) Free air consumption per 10 mm stroke length for a double stroke at 6 bar

Material specification

Piston rod	Stainless steel, DIN X 10 CrNiS 18 9
Piston rod seal	Polyurethane
Piston rod bearing	Multilayer PTFE/steel
End plates	Anodised aluminium
End cap screws	Zink plated steel
O-ring, internal	Nitrile rubber, NBR
Cylinder barrel	Anodised aluminium
Piston	Aluminium
Piston seal	Nitrile rubber, NBR
Piston bearing	UHMWPE-plastic
Magnet	Plastic-bound magnetic material
Bumpers	Polyurethane
Return spring	Surface-treated steel

Variants:

High-temperature version, type G

Piston rod seal	Fluorocarbon rubber, FPM
Piston seal	Fluorocarbon rubber, FPM
O-ring	Fluorocarbon rubber, FPM

Additional data

Working pressure	max 10 bar
Working temperature	max +80 °C min -20 °C

High-temperature version	max +150 °C min -10 °C
--------------------------	---------------------------

Pre-lubricated, further lubrication is not normally necessary. If additional lubrication is introduced it must be continued.

Cushioning diagram

Use the diagram below to determine the necessary size of cylinder to provide the requisite cushioning performance. The maximum cushioning performance, as indicated in the diagram, is based on the following assumptions:

- Low load, i.e. low pressure drop across the piston
- Steady-state piston speed

The load is the sum of the internal and external friction, together with any gravity forces. At high relative loading it is recommended that, for a given speed, the load should be reduced by a factor of 2.5, or that, for a given mass, the speed should be reduced by a factor of 1.5. These factors apply in relation to the maximum performance as shown in the diagram.

Fixed end-cushioning

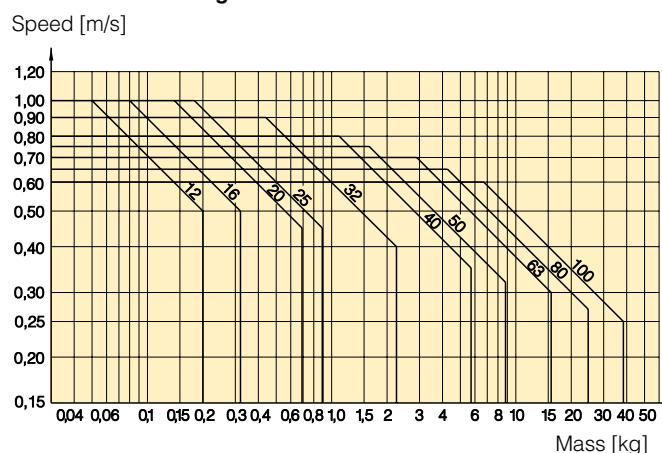

Working medium, air quality

Working medium Dry, filtered compressed air to ISO 8573-1 class 3.4.3.

Recommended air quality for cylinders

For best possible service life and trouble-free operation, ISO 8573-1 quality class 3.4.3 should be used. This means 5 µm filter (standard filter) dew point +3 °C for indoor operation (a lower dew point should be selected for outdoor operation) and oil concentration 1.0 mg oil/m³, which is what a standard compressor with a standard filter gives.

ISO 8573-1 quality classes

Quality class	Pollution particle size (µm)	max concentration (mg/m ³)	Water max. press. dew point (°C)	Oil max concentration (mg/m ³)
1	0,1	0,1	-70	0,01
2	1	1	-40	0,1
3	5	5	-20	1,0
4	15	8	+3	5,0
5	40	10	+7	25
6	-	-	+10	-

Guide for selecting suitable tubing

The selection of the correct size of tubing is often based on experience, with no great thought to optimizing energy efficiency and cylinder velocity. This is usually acceptable, but making a rough calculation can result in worthwhile economic gains.

The following is the basic principle:

1. The primary line to the working valve could be over sized (this does not cause any extra air consumption and consequently does not create any extra costs in operation).
2. The tubes between the valve and the cylinder should, however, be optimized according to the principle that an insufficient bore throttles the flow and thus limits the cylinder speed, while an oversized pipe creates a dead volume which increases the air consumption and filling time.

The chart below is intended to help when selecting the correct size of tube to use between the valve and the cylinder.

The following prerequisites apply:

The cylinder load should be about 50% of the theoretical force (= normal load). A lower load gives a higher velocity and vice versa. The tube size is selected as a function of the cylinder bore, the desired cylinder velocity and the tube length between the valve and the cylinder.

If you want to use the capacity of the valve to its maximum, and obtain maximum speed, the tubing should be chosen so that they at least correspond with the equivalent restriction diameter (see description below), so that the tubing does not restrict the total flow. This means that a short tubing must have at least the equivalent restriction diameter. If the tubing is longer, choose it from the table below. Straight fittings should be chosen for highest flow rates. (Elbow and banjo fittings cause restriction.)

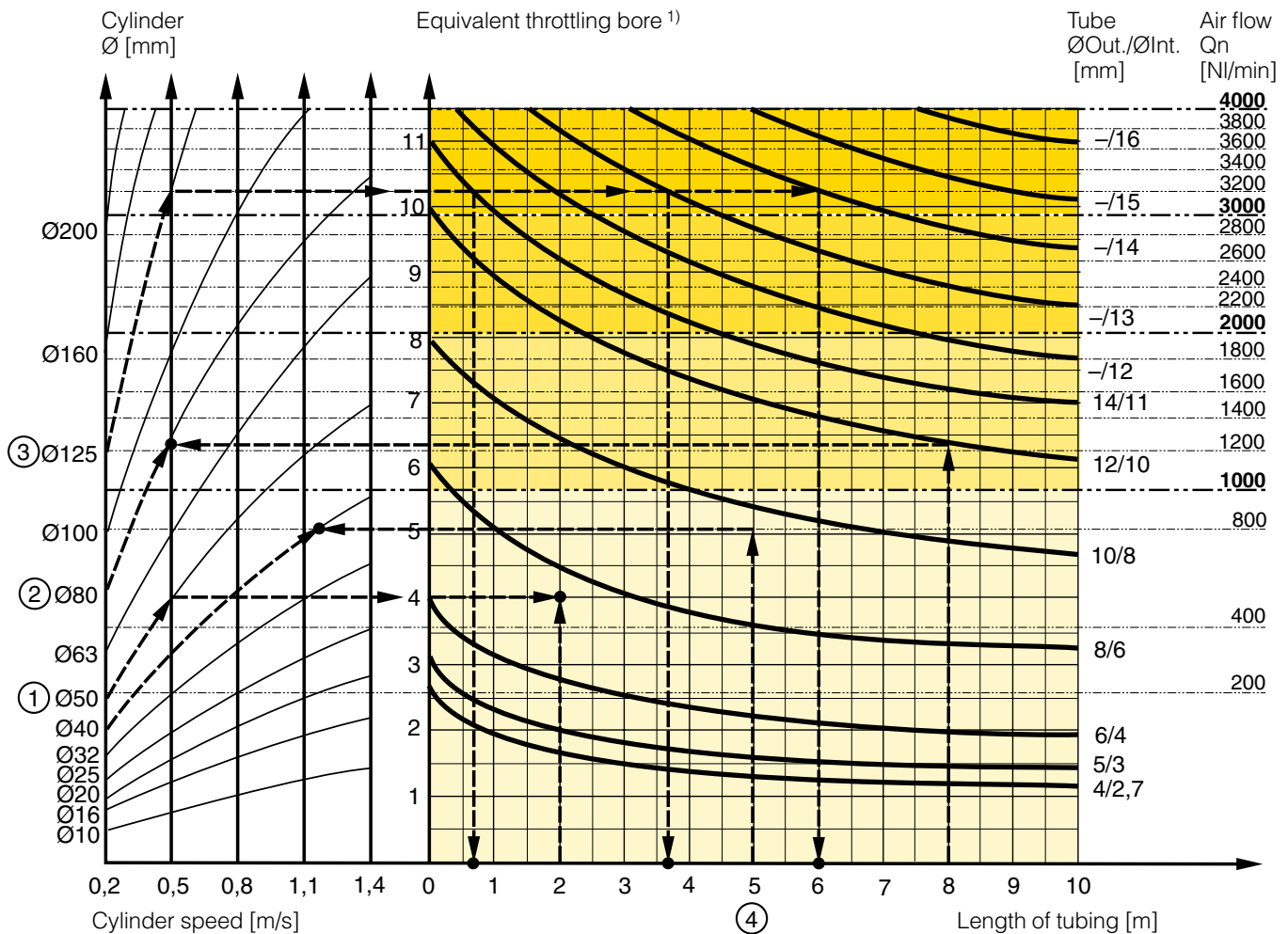

- 1) The "equivalent throttling bore" is a long throttle (for example a tube) or a series of throttles (for example, through a valve) converted to a short throttle which gives a corresponding flow rate. This should not be confused with the "orifice" which is sometimes specified for valves. The value for the orifice does not normally take account of the fact that the valve contains a number of throttles.
- 2) Qn is a measure of the valve flow capacity, with flow measured in litre per minute (l/min) at 6 bar(e) supply pressure and 1 bar pressure drop across the valve.

Example ①: Which tube diameter should be used?

A 50 mm bore cylinder is to be operated at 0.5 m/s. The tube length between the valve and cylinder is 2 m. In the diagram we follow the line from 50 mm bore to 0.5 m/s and get an "equivalent throttling bore" of approximately 4 mm. We continue out to the right in the chart and intersect the line for a 2 m tube between the curves for 4 mm (6/4 tube) and 6 mm (8/6 tube). This means that a 6/4 tube throttles the velocity somewhat, while an 8/6 tube is a little too large. We select the 8/6 tube to obtain full cylinder velocity.

Example ②: What cylinder velocity will be obtained?

A 80 mm bore cylinder will be used, connected by 8 m 12/10 tube to a P2L-B valve. What cylinder velocity will we get? We refer to the diagram and follow the line from 8 mm tube length up to the curve for 12/10 tube. From there, we go horizontally to the curve for the Ø80 cylinder. We find that the velocity will be about 0.5 m/s.

Example ③: What is the minimum inner diameter and maximum length of tube?

For an application a 125 mm bore cylinder will be used. Maximum velocity of piston rod is 0.5 m/s. The cylinder will be controlled by a P2L-D valve. What diameter of tube can be used and what is maximum length of tube. We refer to the diagram. We start at the left side of the diagram cylinder Ø125. We follow the line until the intersection with the velocity line of 0.5 m/s. From here we draw a horizontal line in the diagram. This line shows us we need an equivalent throttling bore of approximately 10 mm. Following this line horizontally we cross a few intersections. These intersections shows us the minimum inner diameter (rightside diagram) in combination with the maximum length of tube (bottomside diagram).

For example:

Intersection one: When a tube (14/11) will be used, the maximum length of tube is 0.7 meter.

Intersection two: When a tube (—/13) will be used, the maximum length of tube is 3.7 meter.

Intersection three: When a tube (—/14) will be used, the maximum length of tube is 6 meter.

Example ④: Determining tube size and cylinder velocity with a particular cylinder and valve?

For an application using a 40 mm bore cylinder with a valve with $Q_n=800$ NI/min. The distance between the cylinder and valve has been set to 5 m.

Tube dimension: What tube bore should be selected to obtain the maximum cylinder velocity? Start at pipe length 5 m, follow the line up to the intersection with 800 NI/min. Select the next largest tube diameter, in this case Ø10/8 mm.

Cylinder velocity: What maximum cylinder velocity will be obtained? Follow the line for 800 NI/min to the left until it intersects with the line for the Ø40 mm cylinder. In this example, the speed is just above 1.1 m/s.

Valve series with respective flows in NI/minute

Valve series	Qn in NI/Min
Valvetronic Solstar	33
Interface PS1	100
Adex A05	173
Moduflex size 1, (2 x 3/2)	220
Valvetronic PVL-B 5/3 closed centre, 6 mm push in	290
Moduflex size 1, (4/2)	320
B43 Manual and mechanical	340
Valvetronic PVL-B 2 x 2/3, 6 mm push in	350
Valvetronic PVL-B 5/3 closed centre, G1/8	370
Compact Isomax DX02	385
Valvetronic PVL-B 2 x 3/2 G1/8	440
Valvetronic PVL-B 5/2, 6 mm push in	450
Valvetronic PVL-B 5/3 vented centre, 6 mm push in	450
Moduflex size 2, (2 x 3/2)	450
Flowstar P2V-A	520
Valvetronic PVL-B 5/3 vented centre, G1/8	540
Valvetronic PVL-B 5/2, G1/8	540
Valvetronic PVL-C 2 x 3/2, 8 mm push in	540
Adex A12	560
Valvetronic PVL-C 2 x 3/2 G1/8	570
Compact Isomax DX01	585
Valvetronic PVL-C 5/3 closed centre, 8 mm push in	700
Valvetronic PVL-C 5/3 vented centre, G1/4	700
VIKING P2L-A	760
B3 Series	780
Valvetronic PVL-C 5/3 closed centre, G1/4	780
Moduflex size 2, (4/2)	800
Valvetronic PVL-C 5/2, 8 mm push in	840
Valvetronic PVL-C 5/3 vented centre, 8 mm push in	840
Valvetronic PVL-C 5/2, G1/4	840
VIKING P2L-B	1020
Flowstar P2V-B	1090
ISOMAX DX1	1150
B53 Manual and mechanical	1160
B4 Series	1170
Airline Isolator Valve VE22/23	1470
ISOMAX DX2	2330
VIKING P2L-D	2880
ISOMAX DX3	4050
Airline Isolator Valve VE42/43	5520
Airline Isolator Valve VE82/83	13680

Dimensions, Double acting standard cylinders

CAD drawings on the Internet

Our home page www.parker.com/euro_pneumatic includes the AirCad Drawing Library with 2D and 3D drawings for the main versions.



Port Position G, J

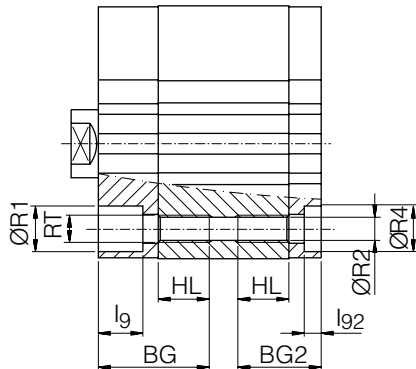

Port Position H

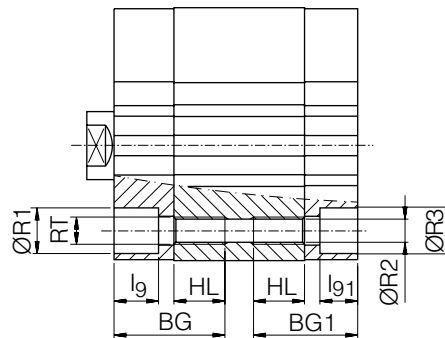

Port Position G

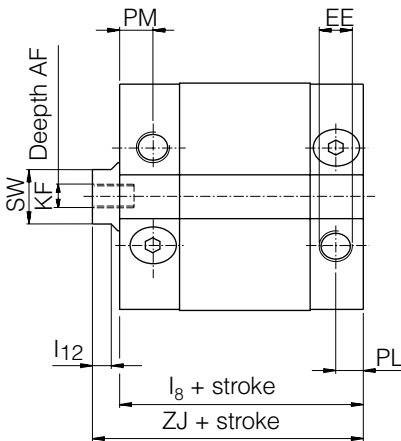

Port Position H

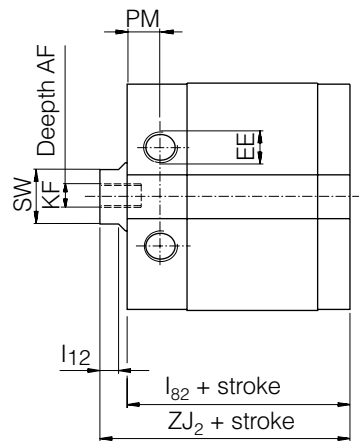

Port Position J

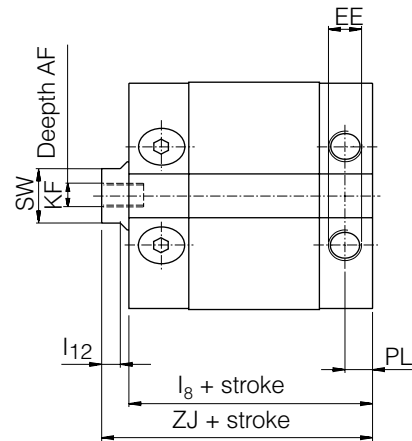

Dimensions

Cylinder designation	AF mm	BG mm	BG1 mm	BG2 mm	EE	HL mm	l8 mm	l9* mm	l12 mm	l82 mm	l91* mm	l92* mm	KF
P1M012	6	25,5	20,5	15,5	M5	12	40,0	3,5	3,0	35,0	3,5	3,5	M3
P1M016	8	26,0	21,0	15,5	M5	12	41,5	5,5	3,0	36,5	3,0	4,0	M4
P1M020	10	32,5	27,0	22,0	M5	18	42,5	10,5	4,0	37,5	5,0	4,5	M5
P1M025	12	32,5	29,0	23,0	M5	18	44,5	4,1	4,0	38,5	4,1	5,0	M6
P1M032	12	41,5	39,0	31,0	G1/8	24	49,0	4,5	5,0	41,0	4,5	4,0	M6
P1M040	12	41,5	39,5	31,0	G1/8	24	50,5	7,2	5,5	42,5	5,2	3,5	M6
P1M050	12	42,5	40,5	34,5	G1/8	25	51,0	5,2	5,5	44,5	5,2	5,0	M8
P1M063	12	43,5	40,5	35,0	G1/8	25	55,5	6,5	5,5	50,0	6,5	4,0	M8
P1M080	14	51,0	51,0	42,0	G1/4	30	63,5	9,5	6,0	54,5	9,5	8,5	M10
P1M100	16	52,0	52,0	43,5	G1/4	30	72,5	9,5	6,0	64,0	9,5	8,5	M12

Cylinder designation	PL mm	PM mm	R1* mm	R2 mm	R3* mm	R4* mm	RT mm	SW	ZJ mm	ZJ2 mm
P1M012	5,0	8,0	6,0	3,5	6,0	6,0	M4	5	43,5	38,5
P1M016	5,0	9,0	7,5	3,5	6,0	6,0	M4	7	45,0	40,0
P1M020	5,0	9,0	10,5	5,0	9,0	9,0	M6	9	47,0	42,0
P1M025	7,0	9,0	10,5	5,0	9,0	9,0	M6	9	49,5	43,5
P1M032	8,0	10,5	10,5	5,0	9,5	9,5	M6	10	57,0	48,5
P1M040	7,5	9,5	10,5	5,0	10,5	10,5	M6	13	58,5	50,5
P1M050	8,0	10,0	14,5	7,0	14,5	11,0	M8	16	59,0	52,5
P1M063	8,0	11,0	10,5	7,0	10,5	10,5	M8	16	63,5	58,0
P1M080	11,5	11,5	14,0	8,5	14,0	14,0	M10	21	73,5	64,5
P1M100	12,0	12,0	14,0	8,5	14,0	14,0	M10	21	84,5	76,0

Length tolerances ± 1 mm Stroke length tolerances $+1,5/0$ mm

Dimensions, Single acting and High temperature variants

CAD drawings on the Internet

Our home page www.parker.com/euro_pneumatic includes the AirCad Drawing Library with 2D and 3D drawings for the main versions.

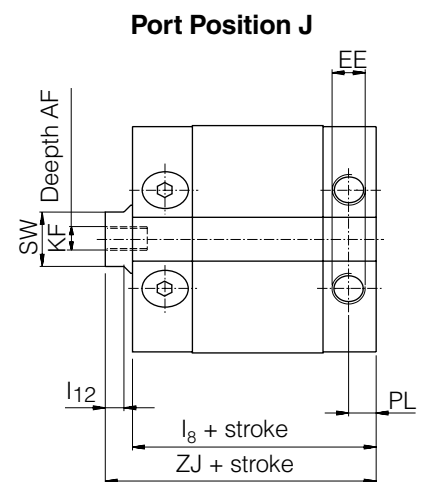
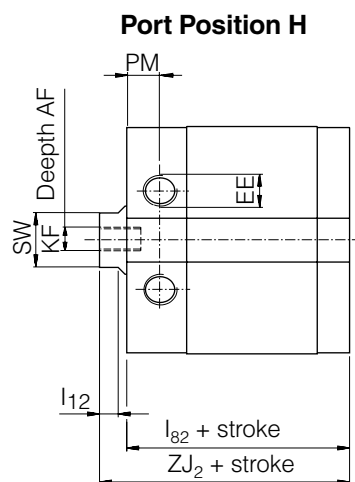
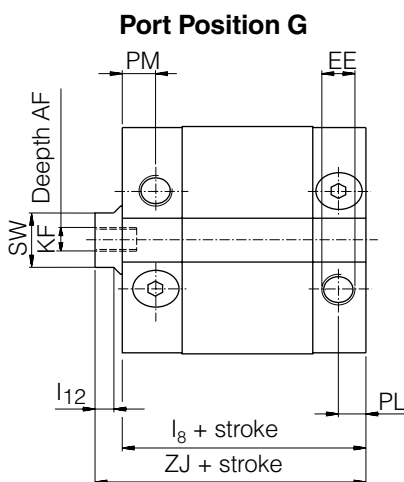
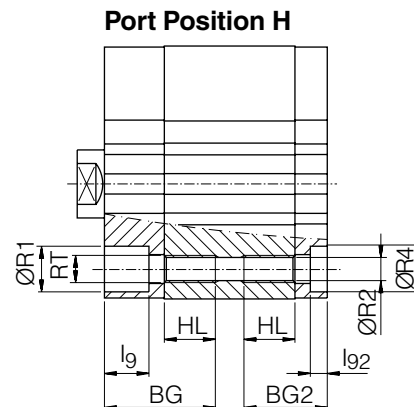
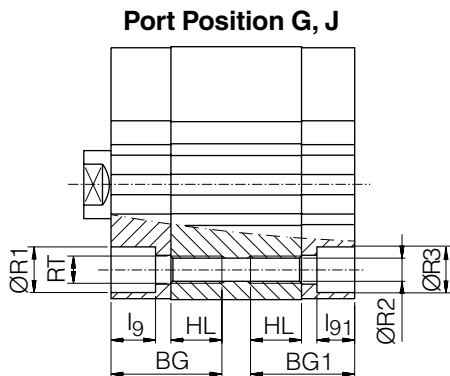

Dimensions

Cylinder designation	AF mm	BG mm	BG1 mm	BG2 mm	EE	HL mm	l8 mm	l9* mm	l12 mm	l82 mm	l91* mm	l92* mm	KF
P1M012	6	25,5	20,5	15,5	M5	12	40,0	3,5	3,0	35,0	3,5	3,5	M3
P1M016	8	26,0	21,0	15,5	M5	12	41,5	5,5	3,0	36,5	3,0	4,0	M4
P1M020	10	32,5	27,0	22,0	M5	18	42,5	10,5	4,0	37,5	5,0	4,5	M5
P1M025	12	32,5	29,0	23,0	M5	18	44,5	10,5	4,0	38,5	7,0	5,0	M6
P1M032	12	41,5	39,0	31,0	G1/8	24	49,0	14,5	5,0	41,0	12,5	4,0	M6
P1M040	12	41,5	39,5	31,0	G1/8	24	50,5	14,0	5,5	42,5	12,0	4,0	M6
P1M050	12	42,5	40,5	34,5	G1/8	25	51,0	13,0	5,5	44,5	11,0	5,0	M8
P1M063	12	43,5	40,5	35,0	G1/8	25	55,5	6,5	5,5	50,0	6,5	6,5	M8
P1M080	14	51,0	51,0	42,0	G1/4	30	63,5	9,5	6,0	54,5	9,5	8,5	M10
P1M100	16	52,0	52,0	43,5	G1/4	30	72,5	9,5	6,0	64,0	9,5	8,5	M12

Cylinder designation	PL mm	PM mm	R1* mm	R2 mm	R3* mm	R4* mm	RT mm	SW mm	ZJ mm	ZJ2 mm
P1M012	5,0	8,0	6,0	3,5	6,0	6,0	M4	5	43,5	38,5
P1M016	5,0	9,0	7,5	3,5	6,0	6,0	M4	7	45,0	40,0
P1M020	5,0	9,0	10,5	5,0	9,0	9,0	M6	9	47,0	42,0
P1M025	7,0	9,0	10,5	5,0	9,0	9,0	M6	9	49,5	43,5
P1M032	8,0	10,5	10,5	5,0	10,5	10,5	M6	10	57,0	48,5
P1M040	7,5	9,5	10,5	5,0	10,5	10,5	M6	13	58,5	50,5
P1M050	8,0	10,0	13,5	7,0	13,5	13,5	M8	16	59,0	52,5
P1M063	8,0	11,0	10,5	7,0	10,5	10,5	M8	16	63,5	58,0
P1M080	11,5	11,5	14,0	8,5	14,0	14,0	M10	21	73,5	64,5
P1M100	12,0	12,0	14,0	8,5	14,0	14,0	M10	21	84,5	76,0

Length tolerances ± 1 mm Stroke length tolerances $+1,5/0$ mm

Dimensions

CAD drawings on the Internet

Our home page www.parker.com/euro_pneumatic includes the AirCad Drawing Library with 2D and 3D drawings for the main versions.



Port Position G, H, J

Bore Ø12 to Ø50 mm

2 mounting holes

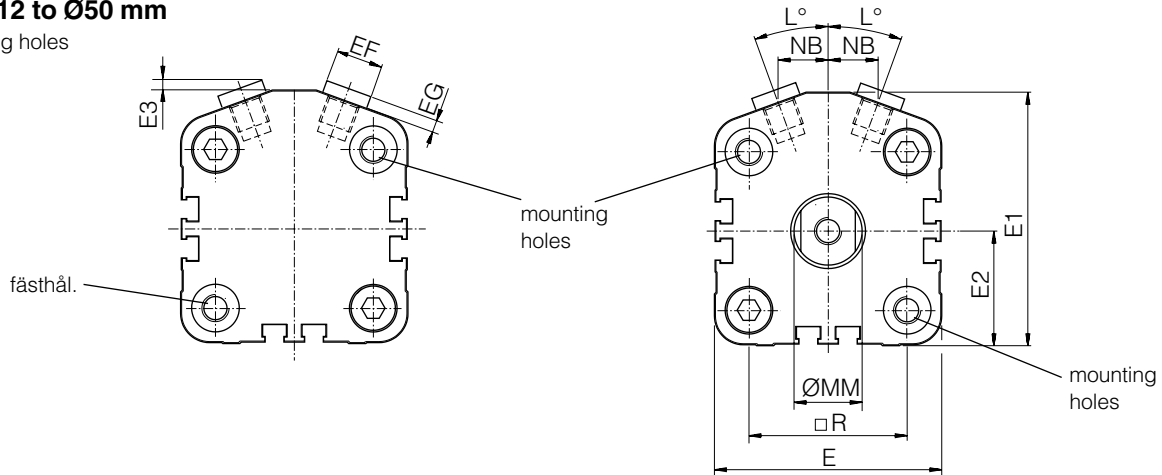

Bore Ø63 to Ø100 mm

4 mounting holes

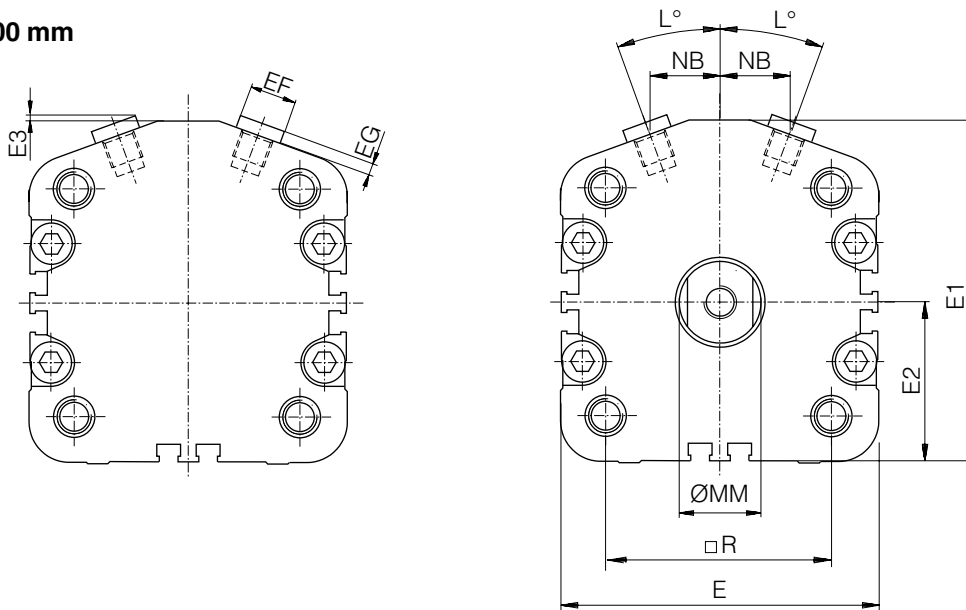

Dimensions

Cylinder designation	E mm	E1 mm	E2 mm	E3 mm	EE mm	EF mm	EG mm	L	MM mm	NB mm	R mm
P1M 012	27,0	31,0	14,0	-	M5	-	-	26°	6	5,5	15,5
P1M 016	31,5	35,0	16,0	-	M5	-	-	20°	8	6,5	20,0
P1M 020	38,5	42,5	19,5	3,5	M5	7*	4,5	20°	10	7,5	25,5
P1M 025	41,5	45,5	21,0	3,5	M5	7*	4,5	20°	10	8,5	28,0
P1M 032	48,0	56,0	24,0	3,0	G1/8	14	2,5	20°	12	9,5	32,5
P1M 040	56,0	62,5	28,0	3,0	G1/8	14	2,5	20°	16	11,5	38,0
P1M 050	67,0	74,5	33,5	3,0	G1/8	14	2,5	20°	20	14,5	46,5
P1M 063	82,0	86,0	40,5	2,5	G1/8	14	2,5	20°	20	17,5	56,5
P1M 080	98,0	106,5	48,5	2,5	G1/4	17	3,0	20°	25	25,5	72,0
P1M 100	119,0	126,5	59,5	2,5	G1/4	17	3,0	20°	25	31,5	89,0

** Hexagon head screw

Dimensions

Cylinder variants

CAD drawings on the Internet

Our home page www.parker.com/euro_pneumatic includes the AirCad Drawing. Library with 2D and 3D drawings for the main versions.



Piston rod thread 8 (external)

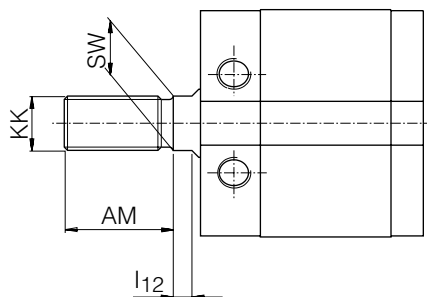

Cylinder type K (through piston rod)

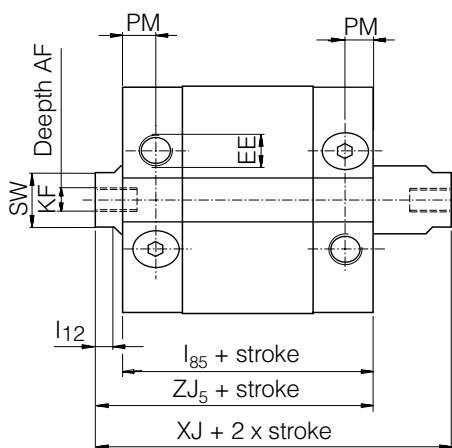

Cylinder type H (hollow, through piston rod)

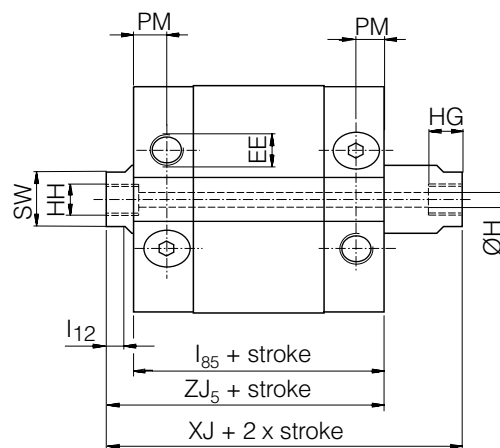

Dimensions

Cylinder designation	AF mm	AM mm	H* mm	HG mm	HH mm	l12 mm	l85 mm	KF mm	KK mm	PM mm	SW mm	XJ mm	ZJ5 mm
P1M 012	6	16	-	-	-	3,0	46,0	M3	M6	8,0	5	54,0	50,0
P1M 016	8	20	-	-	-	3,0	47,5	M4	M6	9,0	7	54,5	51,5
P1M 020	10	22	3	7	M5	4,0	49,5	M5	M8	9,0	9	58,5	54,0
P1M 025	12	22	3	7	M5	4,0	49,5	M6	M10X1,25	9,0	9	60,0	55,0
P1M 032	12	22	3	7	G1/8	5,0	51,5	M6	M10X1,25	10,5	10	67,5	59,5
P1M 040	12	24	4	8	G1/8	5,5	52,5	M6	M12X1,25	9,5	13	69,0	60,5
P1M 050	12	32	5	8	G1/8	5,5	53,0	M8	M16X1,5	10,0	16	69,0	61,0
P1M 063	12	32	5	8	G1/8	5,5	58,5	M8	M16X1,5	11,0	16	75,0	66,5
P1M 080	14	40	6	11	G1/4	6,0	63,5	M10	M20X1,5	11,5	21	84,0	73,5
P1M 100	16	40	6	11	G1/4	6,0	72,5	M12	M20X1,5	12,0	21	97,0	84,5

* Dimension H only for cylinder H

Length tolerances ±1 mm

Stroke length tolerances +1,5/0 mm

Order key

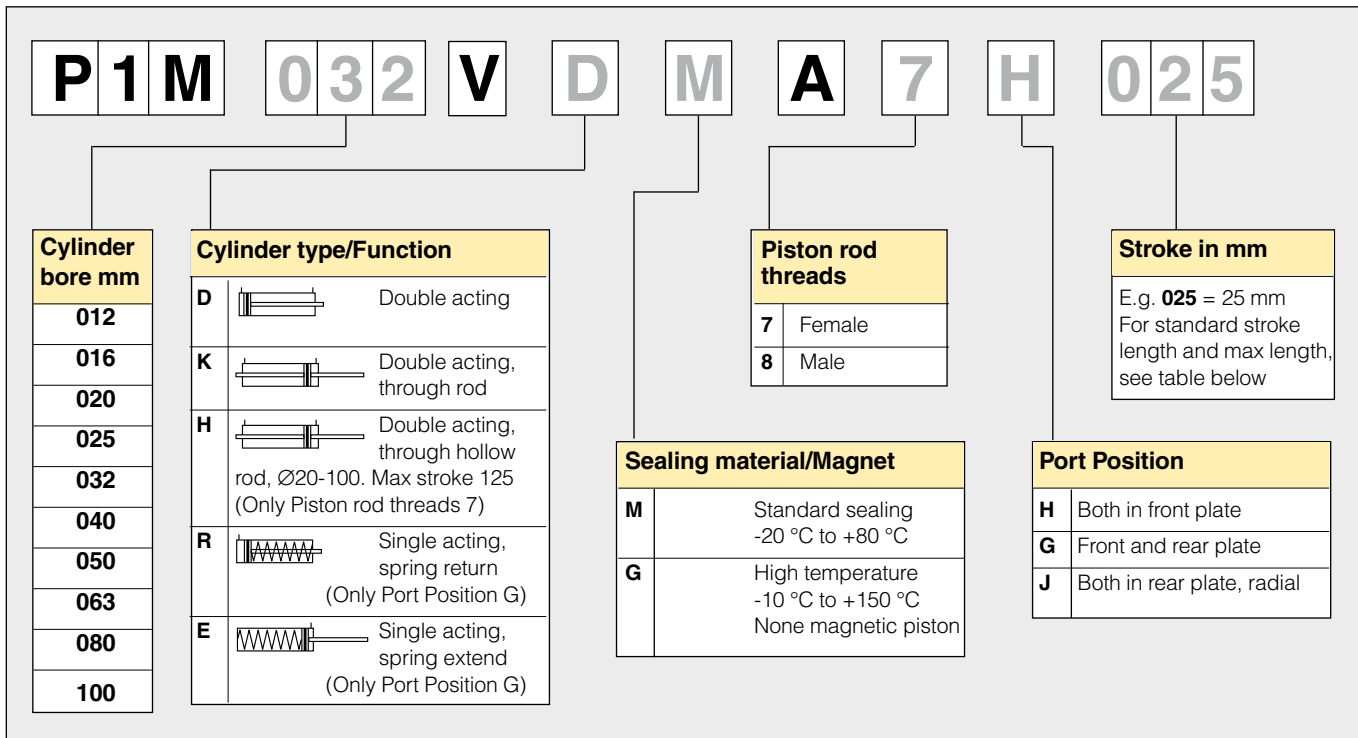

Standard stroke length in mm

Standard stroke lengths in mm according to ISO 4393. Special strokes up to: see yellow fields in figure below

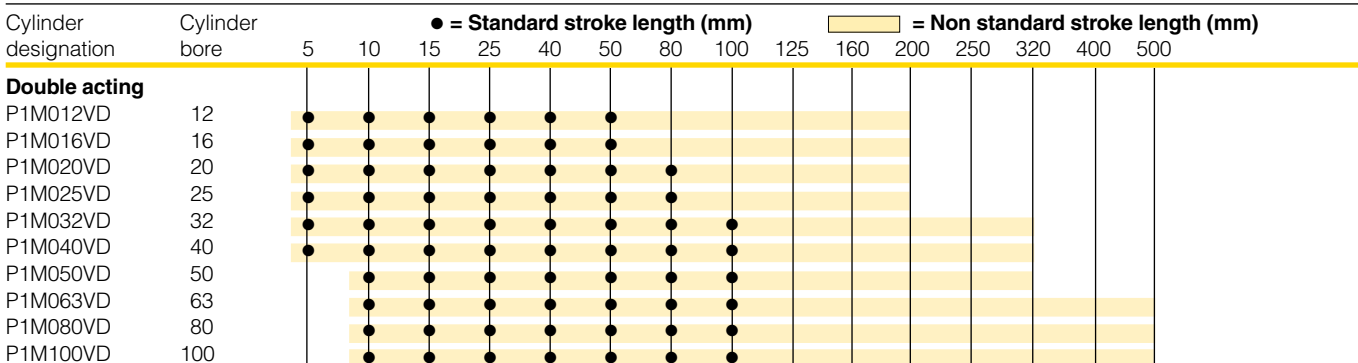

Single acting, spring return

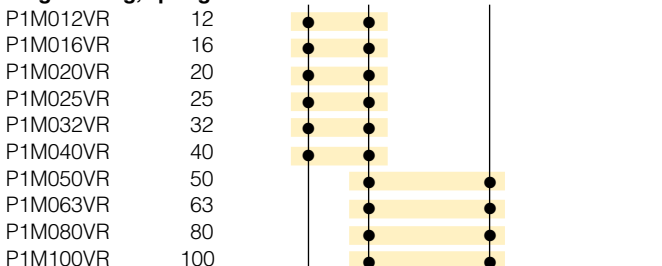

Single acting, spring extended

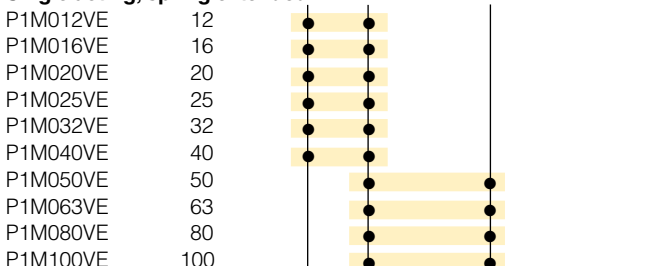

Port options

P1M cylinders with diameters 25 to 100 mm and port positions G and J are equipped with four ports, two in the front plate and two in the rear plate. Two plugs are then fitted in order to obtain port position G or J.

This allows any user to move these plugs at any time in order to produce the following port options:

- One port each at front and rear, position G
- One port each at front and rear with the plugs a mirror image of position G
- Both ports at rear, position J
- Both ports at front (note that this lengthens the installed dimensions compared with option H, which has very short installed dimensions)

Double acting

Ports in front and rear plate, female piston rod thread

Ø12 and Ø16 are two-port variants, the rest are four-port variants with two plugs. See also the port options page on the previous page

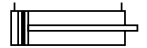

Cyl. bore mm	Stroke mm	Order code	
12 M5 thread	5	P1M012VDMA7G005	
	10	P1M012VDMA7G010	
	25	P1M012VDMA7G025	
	40	P1M012VDMA7G040	
	50	P1M012VDMA7G050	
	80	P1M012VDMA7G080	
	100	P1M012VDMA7G100	
	125	P1M012VDMA7G125	
	160	P1M012VDMA7G160	
	200	P1M012VDMA7G200	
16 M5 thread	5	P1M016VDMA7G005	
	10	P1M016VDMA7G010	
	25	P1M016VDMA7G025	
	40	P1M016VDMA7G040	
	50	P1M016VDMA7G050	
	80	P1M016VDMA7G080	
	100	P1M016VDMA7G100	
	125	P1M016VDMA7G125	
	160	P1M016VDMA7G160	
	200	P1M016VDMA7G200	
20 M5 thread	5	P1M020VDMA7G005	
	10	P1M020VDMA7G010	
	25	P1M020VDMA7G025	
	40	P1M020VDMA7G040	
	50	P1M020VDMA7G050	
	80	P1M020VDMA7G080	
	100	P1M020VDMA7G100	
	125	P1M020VDMA7G125	
	160	P1M020VDMA7G160	
	200	P1M020VDMA7G200	
25 M5 thread	5	P1M025VDMA7G005	
	10	P1M025VDMA7G010	
	25	P1M025VDMA7G025	
	40	P1M025VDMA7G040	
	50	P1M025VDMA7G050	
	80	P1M025VDMA7G080	
	100	P1M025VDMA7G100	
	125	P1M025VDMA7G125	
	160	P1M025VDMA7G160	
	200	P1M025VDMA7G200	
	32 G1/8 thread	5	P1M032VDMA7G005
		10	P1M032VDMA7G010
25		P1M032VDMA7G025	
40		P1M032VDMA7G040	
50		P1M032VDMA7G050	
80		P1M032VDMA7G080	
100		P1M032VDMA7G100	
125		P1M032VDMA7G125	
160		P1M032VDMA7G160	
200		P1M032VDMA7G200	
250		P1M032VDMA7G250	
320		P1M032VDMA7G320	
40 G1/8 thread		5	P1M040VDMA7G005
		10	P1M040VDMA7G010
	25	P1M040VDMA7G025	
	40	P1M040VDMA7G040	
	50	P1M040VDMA7G050	
	80	P1M040VDMA7G080	
	100	P1M040VDMA7G100	
	125	P1M040VDMA7G125	
	160	P1M040VDMA7G160	
	200	P1M040VDMA7G200	
	250	P1M040VDMA7G250	
	320	P1M040VDMA7G320	

Cyl. bore mm	Stroke mm	Order code
50 G1/8 thread	5	P1M050VDMA7G005
	10	P1M050VDMA7G010
	25	P1M050VDMA7G025
	40	P1M050VDMA7G040
	50	P1M050VDMA7G050
	80	P1M050VDMA7G080
	100	P1M050VDMA7G100
	125	P1M050VDMA7G125
	160	P1M050VDMA7G160
	200	P1M050VDMA7G200
	250	P1M050VDMA7G250
	320	P1M050VDMA7G320
63 G1/8 thread	5	P1M063VDMA7G005
	10	P1M063VDMA7G010
	25	P1M063VDMA7G025
	40	P1M063VDMA7G040
	50	P1M063VDMA7G050
	80	P1M063VDMA7G080
	100	P1M063VDMA7G100
	125	P1M063VDMA7G125
	160	P1M063VDMA7G160
	200	P1M063VDMA7G200
	250	P1M063VDMA7G250
	320	P1M063VDMA7G320
80 G1/4 thread	5	P1M080VDMA7G005
	10	P1M080VDMA7G010
	25	P1M080VDMA7G025
	40	P1M080VDMA7G040
	50	P1M080VDMA7G050
	80	P1M080VDMA7G080
	100	P1M080VDMA7G100
	125	P1M080VDMA7G125
	160	P1M080VDMA7G160
	200	P1M080VDMA7G200
	250	P1M080VDMA7G250
	320	P1M080VDMA7G320
100 G1/4 thread	5	P1M063VDMA7G005
	10	P1M063VDMA7G010
	25	P1M063VDMA7G025
	40	P1M063VDMA7G040
	50	P1M063VDMA7G050
	80	P1M063VDMA7G080
	100	P1M063VDMA7G100
	125	P1M063VDMA7G125
	160	P1M063VDMA7G160
	200	P1M063VDMA7G200
	250	P1M063VDMA7G250
	320	P1M063VDMA7G320
100 G1/4 thread	400	P1M100VDMA7G400
	500	P1M100VDMA7G500

Double acting

Both ports in front plate, female piston rod thread

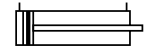

Cyl. bore mm	Stroke mm	Order code	
12 M5 thread	5	P1M012VDMA7H005	
	10	P1M012VDMA7H010	
	25	P1M012VDMA7H025	
	40	P1M012VDMA7H040	
	50	P1M012VDMA7H050	
	80	P1M012VDMA7H080	
	100	P1M012VDMA7H100	
	125	P1M012VDMA7H125	
	160	P1M012VDMA7H160	
	200	P1M012VDMA7H200	
16 M5 thread	5	P1M016VDMA7H005	
	10	P1M016VDMA7H010	
	25	P1M016VDMA7H025	
	40	P1M016VDMA7H040	
	50	P1M016VDMA7H050	
	80	P1M016VDMA7H080	
	100	P1M016VDMA7H100	
	125	P1M016VDMA7H125	
	160	P1M016VDMA7H160	
	200	P1M016VDMA7H200	
20 M5 thread	5	P1M020VDMA7H005	
	10	P1M020VDMA7H010	
	25	P1M020VDMA7H025	
	40	P1M020VDMA7H040	
	50	P1M020VDMA7H050	
	80	P1M020VDMA7H080	
	100	P1M020VDMA7H100	
	125	P1M020VDMA7H125	
	160	P1M020VDMA7H160	
	200	P1M020VDMA7H200	
25 M5 thread	5	P1M025VDMA7H005	
	10	P1M025VDMA7H010	
	25	P1M025VDMA7H025	
	40	P1M025VDMA7H040	
	50	P1M025VDMA7H050	
	80	P1M025VDMA7H080	
	100	P1M025VDMA7H100	
	125	P1M025VDMA7H125	
	160	P1M025VDMA7H160	
	200	P1M025VDMA7H200	
32 G1/8 thread	5	P1M032VDMA7H005	
	10	P1M032VDMA7H010	
	25	P1M032VDMA7H025	
	40	P1M032VDMA7H040	
	50	P1M032VDMA7H050	
	80	P1M032VDMA7H080	
	100	P1M032VDMA7H100	
	125	P1M032VDMA7H125	
	160	P1M032VDMA7H160	
	200	P1M032VDMA7H200	
	250	P1M032VDMA7H250	
	320	P1M032VDMA7H320	
	40 G1/8 thread	5	P1M040VDMA7H005
		10	P1M040VDMA7H010
25		P1M040VDMA7H025	
40		P1M040VDMA7H040	
50		P1M040VDMA7H050	
80		P1M040VDMA7H080	
100		P1M040VDMA7H100	
125		P1M040VDMA7H125	
160		P1M040VDMA7H160	
200		P1M040VDMA7H200	
250		P1M040VDMA7H250	
320		P1M040VDMA7H320	

Cyl. bore mm	Stroke mm	Order code
50 G1/8 thread	5	P1M050VDMA7H005
	10	P1M050VDMA7H010
	25	P1M050VDMA7H025
	40	P1M050VDMA7H040
	50	P1M050VDMA7H050
	80	P1M050VDMA7H080
	100	P1M050VDMA7H100
	125	P1M050VDMA7H125
	160	P1M050VDMA7H160
	200	P1M050VDMA7H200
	250	P1M050VDMA7H250
	320	P1M050VDMA7H320
	63 G1/8 thread	5
10		P1M063VDMA7H010
25		P1M063VDMA7H025
40		P1M063VDMA7H040
50		P1M063VDMA7H050
80		P1M063VDMA7H080
100		P1M063VDMA7H100
125		P1M063VDMA7H125
160		P1M063VDMA7H160
200		P1M063VDMA7H200
250		P1M063VDMA7H250
320		P1M063VDMA7H320
400		P1M063VDMA7H400
500		P1M063VDMA7H500
80 G1/4 thread	5	P1M080VDMA7H005
	10	P1M080VDMA7H010
	25	P1M080VDMA7H025
	40	P1M080VDMA7H040
	50	P1M080VDMA7H050
	80	P1M080VDMA7H080
	100	P1M080VDMA7H100
	125	P1M080VDMA7H125
	160	P1M080VDMA7H160
	200	P1M080VDMA7H200
	250	P1M080VDMA7H250
	320	P1M080VDMA7H320
	400	P1M080VDMA7H400
	500	P1M080VDMA7H500
100 G1/4 thread	5	P1M063VDMA7H005
	10	P1M063VDMA7H010
	25	P1M063VDMA7H025
	40	P1M063VDMA7H040
	50	P1M063VDMA7H050
	80	P1M063VDMA7H080
	100	P1M063VDMA7H100
	125	P1M063VDMA7H125
	160	P1M063VDMA7H160
	200	P1M063VDMA7H200
	250	P1M063VDMA7H250
	320	P1M063VDMA7H320
	400	P1M100VDMA7H400
	500	P1M100VDMA7H500

Single acting

Spring return, female piston rod thread

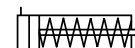

Cyl. bore mm	Stroke mm	Order code
12	5	P1M012VRMA7G005
M5 thread	10	P1M012VRMA7G010
16	5	P1M016VRMA7G005
M5 thread	10	P1M016VRMA7G010
20	5	P1M020VRMA7G005
M5 thread	10	P1M020VRMA7G010
25	5	P1M025VRMA7G005
M5 thread	10	P1M025VRMA7G010
32	5	P1M032VRMA7G005
G1/8 thread	10	P1M032VRMA7G010
40	5	P1M040VRMA7G005
G1/8 thread	10	P1M040VRMA7G010
50	5	P1M050VRMA7G005
G1/8 thread	10	P1M050VRMA7G010
63	5	P1M063VRMA7G005
G1/8 thread	10	P1M063VRMA7G010
80	5	P1M080VRMA7G005
G1/4 thread	10	P1M080VRMA7G010
100	5	P1M063VRMA7G005
G1/4 thread	10	P1M063VRMA7G010

Cylinder mountings

Type	Description	Cyl. bore Ø mm	Mass kg	Order code
Flange MF1/MF2 	Intended for fixed mounting of cylinder. Flange can be fitted to front- or rear end-plates of cylinder. Materials Flange: Surface-treated steel, black Mounting screws according to DIN 6912: Zinc-plated steel 8.8 Supplied complete with mounting screws for attachment to cylinder.	12	0,08	P1M-4DMB P1M-4FMB P1M-4HMB P1M-4JMB P1C-4KMB P1C-4LMB P1C-4MMB P1C-4NMB P1C-4PMB P1C-4QMB
		16	0,10	
		20	0,16	
		25	0,20	
		32	0,23	
		40	0,28	
		50	0,53	
		63	0,71	
		80	1,59	
		100	2,19	

Ø32-100 according to ISO MF1/MF2, VDMA, AFNOR

Cyl. bore mm	d1 mm	FB mm	TG1 mm	E mm	R mm	MF mm	TF mm	UF mm	I1 mm	W mm	ZF* mm	ZB* mm	ZF2* mm	ZB2* mm
	H11	H13				JS14	JS14	JS14	-0,5					
12	9,0	4,5	15,5	25	-	5,5	45,0	55	3,0	2,0	44,0	38,5	49,0	43,5
16	11,5	4,5	20,0	30	-	5,5	45,0	55	3,0	2,0	45,5	40,0	50,5	45,0
20	14,0	6,6	25,5	39	-	8,0	50,5	62	4,2	4,5	49,0	41,0	54,0	46,0
25	14,0	6,6	28,0	42	-	8,0	53,0	65	4,2	3,0	51,5	43,5	56,5	49,5
32	30,0	7,0	32,5	45	32	10,0	64,0	80	5,0	2,0	58,5	48,5	67,0	57,0
40	35,0	9,0	38,0	52	36	10,0	72,0	90	5,0	2,0	60,5	50,5	68,5	58,5
50	40,0	9,0	46,5	65	45	12,0	90,0	110	6,5	4,0	64,5	52,5	71,0	59,0
63	45,0	9,0	56,5	75	50	12,0	100,0	120	6,5	4,0	70,0	58,0	75,5	63,5
80	45,0	12,0	72,0	95	63	16,0	126,0	150	8,0	6,0	80,5	64,5	89,5	73,5
100	55,0	14,0	89,0	115	75	16,0	150,0	170	8,0	4,0	92,0	76,0	100,5	84,5

S = Stroke length

* ZF, ZB for cylinders with both ports in front end (type H)
ZF2, ZB2 for all other cylinders (type G, J, K)

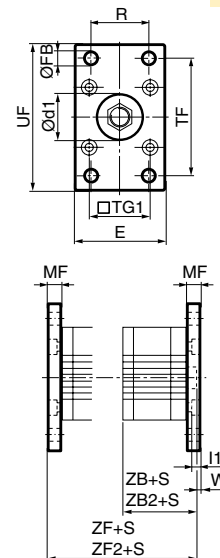

Angle bracket MS1



Intended for fixed mounting of cylinder. Angle bracket can be fitted to front- and rear end-plates of cylinder.

Materials
Angle bracket:
Bore 12-25 mm, Zinc-plated steel
Bore 32-50 mm, Surface-treated aluminium, black
Bore 63-100 mm, Surface-treated steel, black
Mounting screws:
according to DIN 912: Zinc-plated steel 8.8

Supplied in pairs with mounting screws for attachment to cylinder.

12	0,02*
16	0,02*
20	0,04*
25	0,05*
32	0,06*
40	0,08*
50	0,16*
63	0,25*
80	0,50*
100	0,85*

* Weight per item

P1M-4DMF
P1M-4FMF
P1M-4HMF
P1M-4JMF
P1C-4KMZ
P1C-4LMZ
P1C-4MMZ
P1C-4NMF
P1C-4PMF
P1C-4QMF

Ø32-100 according to ISO MS1, VDMA, AFNOR

Cyl. bore mm	AB mm	TG1 mm	E mm	TR mm	AO mm	AU mm	AH mm	I7 mm	AT mm	I9 mm	I8 mm	SA* mm	SA2* mm
	H14			JS14			JS15		JS14				
12	4,5	15,5	44	35	5,5	8,0	17	29,5	2	-	8	51,0	56,0
16	4,5	20,0	48	39	6,0	8,0	19	33,5	2	-	10	52,5	57,5
20	6,6	25,5	62	50	7,5	9,0	24	42,0	3,2	-	12	59,5	64,5
25	6,6	28,0	66	52	7,5	10,5	26	46,0	3,2	-	12	59,5	65,5
32	7,0	32,5	45	32	11,0	24,0	32	54,5	8,0	-	30	88,5	97,0
40	9,0	38,0	52	36	7,0	28,0	36	62,0	8,0	-	35	98,5	106,5
50	9,0	46,5	65	45	13,0	32,0	45	77,5	10,0	-	40	108,5	115,0
63	9,0	56,5	75	50	13,0	32,0	50	35,0	5,5	27,5	-	114,0	119,5
80	12,0	72,0	95	63	14,0	41,0	63	49,0	6,5	40,5	-	136,5	145,5
100	14,0	89,0	115	75	15,0	41,0	71	54,0	6,5	43,5	-	146,0	154,5

S = Stroke length

* SA for cylinders with both ports in front end (type H)
* SA2 for all other cylinders (type G, J, K)

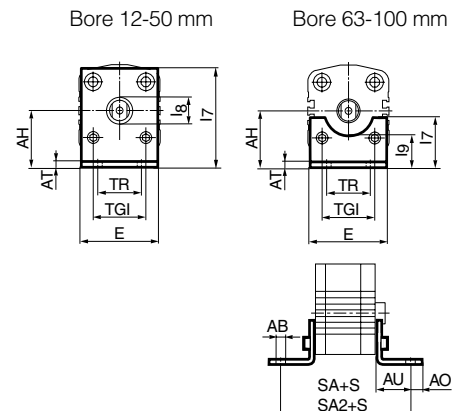

Cylinder mountings

Type	Description	Cyl. bore Ø mm	Mass kg	Order code
Pivot bracket with rigid bearing	Intended for flexible mounting of cylinder. The pivot bracket can be combined with clevis bracket MP2. Materials Pivot bracket: Surface-treated aluminium, black Bearing: Sintered oil-bronze bushing	32	0,06	P1C-4KMD P1C-4LMD P1C-4MMD P1C-4NMD P1C-4PMD P1C-4QMD
		40	0,08	
		50	0,15	
		63	0,20	
		80	0,33	
		100	0,49	

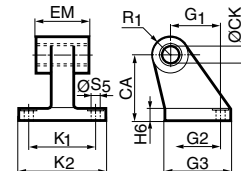

Ø32-100 according to CETOP RP 107 P, VDMA, AFNOR

Cyl. bore mm	CK	S5	K1	K2	G1	G2	EM	G3	CA	H6	R1
	H9	H13	JS14		JS14	JS14			JS15		
	mm	mm	mm	mm	mm	mm	mm	mm	mm	mm	mm
32	10	6,6	38	51	21	18	25,5	31	32	8	10
40	12	6,6	41	54	24	22	27,0	35	36	10	11
50	12	9,0	50	65	33	30	31,0	45	45	12	13
63	16	9,0	52	67	37	35	39,0	50	50	12	15
80	16	11,0	66	86	47	40	49,0	60	63	14	15
100	20	11,0	76	96	55	50	59,0	70	71	15	19

Clevis bracket MP2



Intended for flexible mounting of cylinder. Clevis bracket MP2 can be combined with clevis bracket MP4.

Materials
Clevis bracket: Surface-treated aluminium, black
Mounting screws according to DIN 912:
Zinc-plated steel 8.8
Pin: surface treated steel

Supplied complete with mounting screws for attachment to cylinder.

12	0,02
16	0,03
20	0,05
25	0,06
32	0,08
40	0,11
50	0,14
63	0,29
80	0,36
100	0,64

P1M-4DMT
P1M-4FMT
P1M-4HMT
P1M-4JMT
P1C-4KMT
P1C-4LMT
P1C-4MMT
P1C-4NMT
P1C-4PMT
P1C-4QMT

Ø32-100 according to ISO MP2, VDMA, AFNOR

Cyl. bore mm	E	UB	CB	FL	L	l2	CD	MR	XD*	XD2*
	mm	h14	H14	±0,2			H9			
	mm	mm	mm	mm	mm	mm	mm	mm	mm	mm
12	27,0	10	5,2	14	7	-	5	6	52,5	57,5
16	31,5	12	6,7	15	10	-	5	6	55,0	60,0
20	38,5	16	8,2	18	12	-	8	9	59,0	65,0
25	41,0	20	10,2	20	14	-	10	10	63,5	69,5
32	45,0	25	12,2	22	16	-	12	12	67,5	73,5
40	52,0	32	15,2	25	20	-	15	15	75,5	81,5
50	65,0	40	19,2	27	24	-	18	18	87,5	93,5
63	75,0	50	24,2	32	30	-	22	22	101,5	107,5
80	95,0	63	30,2	36	36	-	26	26	121,5	127,5
100	115,0	80	38,2	41	42	-	30	30	141,5	147,5

S = Stroke length

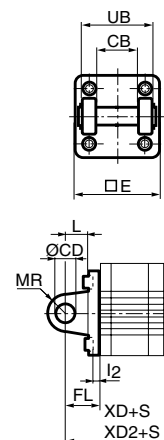

* XD for cylinders with both ports in front end (type H)
XD2 for all other cylinders (type G, J, K)

Cylinder mountings

Type	Description	Cyl. bore Ø mm	Mass kg	Order code
Clevis bracket MP4 	Intended for flexible mounting of cylinder. Clevis bracket MP4 can be combined with clevis bracket MP2. Materials Clevis bracket: Surface-treated aluminium, black Mounting screws according to DIN 912: Zinc-plated steel 8.8 Supplied complete with mounting screws for attachment to cylinder.	12	0,02	P1M-4DME P1M-4FME P1M-4HME P1M-4JME P1C-4KME P1C-4LME P1C-4MME P1C-4NME P1C-4PME P1C-4QME
		16	0,03	
		20	0,05	
		25	0,07	
		32	0,09	
		40	0,13	
		50	0,17	
		63	0,36	
		80	0,46	
		100	0,83	

Ø32-100 according to ISO MP4, VDMA, AFNOR

Cyl. bore mm	E	EW	FL ±0,2	L	I2	CD H9	MR	XD*	XD2*
12	27,0	4,7	14	7	-	5	6	52,5	57,5
16	31,5	6,2	15	10	-	5	6	55,0	60,0
20	38,5	7,7	18	12	-	8	9	59,0	65,0
25	41,0	9,7	20	14	-	10	10	63,5	69,5
32	45,0	26,0	22	13	5,5	10	10	70,5	79,0
40	52,0	28,0	25	16	5,5	12	12	75,5	83,5
50	65,0	32,0	27	16	6,5	12	12	79,5	86,0
63	75,0	40,0	32	21	6,5	16	16	90,0	95,5
80	95,0	50,0	36	22	10,0	16	16	100,5	109,5
100	115,0	60,0	41	27	10,0	20	20	117,0	125,5

S = Stroke length

* XD for cylinders with both ports in front end (type H)
XD2 for all other cylinders (type G, J, K)

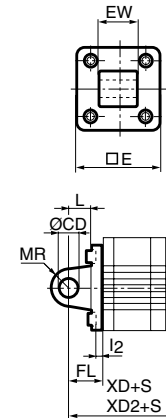

Clevis bracket GA

	Intended for flexible mounting of cylinder. Clevis bracket GA can be combined with pivot bracket with swivel bearing, swivel eye bracket and swivel rod eye. Materials Clevis bracket: Surface-treated aluminium Pin: Surface hardened steel Locking pin: Spring steel Circlips according to DIN 471: Spring steel Mounting screws acc. to DIN 912: Zinc-plated steel 8.8 Supplied complete with mounting screws for attachment to cylinder.	32	0,09	P1C-4KMCA P1C-4LMCA P1C-4MMCA P1C-4NMCA P1C-4PMCA P1C-4QMCA
		40	0,13	
		50	0,17	
		63	0,36	
		80	0,58	
		100	0,89	

According to VDMA, AFNOR

Cyl. bore mm	E	B2 d12	B1 H14	T	B3	R2	L1	FL ±0,2	I2	L	CN F7	R1	XD*	XD2*
32	45	34	14	3	3,3	17	11,5	22	5,5	12	10	11	70,5	79,0
40	52	40	16	4	4,3	20	12,0	25	5,5	15	12	13	75,5	83,5
50	65	45	21	4	4,3	22	14,0	27	6,5	17	16	18	79,5	86,0
63	75	51	21	4	4,3	25	14,0	32	6,5	20	16	18	90,0	95,5
80	95	65	25	4	4,3	30	16,0	36	10,0	20	20	22	100,5	109,5
100	115	75	25	4	4,3	32	16,0	41	10,0	25	20	22	117,0	125,5

S = Stroke length

* XD for cylinders with both ports in front end (type H)
XD2 for all other cylinders (type G, J, K)

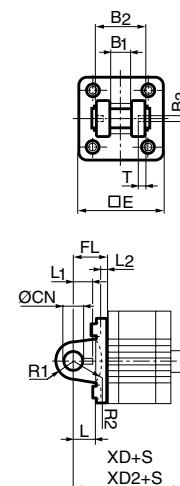

Stainless steel Pin Set GA

Materials:
Pin: Stainless steel
Locking pin: Stainless steel
Circlips according to DIN 471: Stainless steel

32	0,05	9301054311
40	0,06	9301054312
50	0,07	9301054313
63	0,07	9301054314
80	0,17	9301054315
100	0,31	9301054316

Cylinder mountings

Type	Description	Cyl. bore Ø mm	Mass kg	Order code
Pivot bracket with swivel bearing	Intended for use together with clevis bracket GA.	32	0,18	P1C-4KMA P1C-4LMA P1C-4MMA P1C-4NMA P1C-4PMA P1C-4QMA
	Material	40	0,25	
	Pivot bracket: Surface-treated steel, black	50	0,47	
	Swivel bearing according to DIN 648K: Hardened steel	63	0,57	
		80	1,05	
		100	1,42	

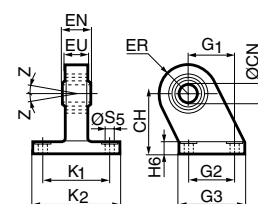
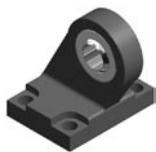

According to VDMA, AFNOR

Cyl. bore mm	CN mm	S5 mm	K1 mm	K2 mm	EU mm	G1 mm	G2 mm	EN mm	G3 mm	CH mm	H6 mm	ER mm	Z mm
32	10	6,6	38	51	10,5	21	18	14	31	32	10	16	4°
40	12	6,6	41	54	12,0	24	22	16	35	36	10	18	4°
50	16	9,0	50	65	15,0	33	30	21	45	45	12	21	4°
63	16	9,0	52	67	15,0	37	35	21	50	50	12	23	4°
80	20	11,0	66	86	18,0	47	40	25	60	63	14	28	4°
100	20	11,0	76	96	18,0	55	50	25	70	71	15	30	4°

Swivel eye bracket

Swivel eye bracket	Intended for use together with clevis bracket GA	32	0,08	P1C-4KMSA P1C-4LMSA P1C-4MMSA P1C-4NMSA P1C-4PMSA P1C-4QMSA
	Material	40	0,11	
	Bracket: Surface-treated aluminium, black	50	0,20	
	Swivel bearing acc. to DIN 648K: Hardened steel	63	0,27	
		80	0,52	
	Supplied complete with mounting screws for attachment to cylinder.	100	0,72	



According to VDMA, AFNOR

Cyl. bore mm	E mm	B1 mm	B2 mm	EN mm	R1 mm	R2 mm	FL mm	I2 mm	L mm	CN mm	XD* mm	XD2* mm	Z mm
32	45	10,5	38	14	16	14	22	5,5	12	10	70,5	79,0	4°
40	52	12,0	44	16	18	16	25	5,5	15	12	75,5	83,5	4°
50	65	15,0	51	21	21	19	27	6,5	15	16	79,5	86,0	4°
63	75	15,0	56	21	23	22	32	6,5	20	16	90,0	95,5	4°
80	95	18,0	72	25	29	25	36	10,0	20	20	100,5	109,5	4°
100	115	18,0	82	25	31	27	41	10,0	25	20	117,0	125,5	4°

S=Stroke length

* XD for cylinders with both ports in front end (type H)
XD2 for all other cylinders (type G, J, K)

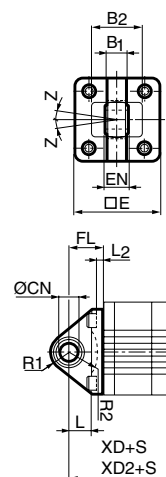

Cylinder mountings



Type	Description	Cyl. bore Ø mm	Mass kg	Order code
Mounting kit	Mounting kit for back to back mounted cylinders, 3 and 4 position cylinders. Material: Mounting, Aluminium Mounting screws, Zinc-plated steel 8.8	32	0,060	P1E-6KB0 P1E-6LB0 P1E-6MB0 P1E-6NB0 P1E-6PB0 P1E-6QB0
		40	0,078	
		50	0,162	
		63	0,194	
		80	0,450	
		100	0,672	

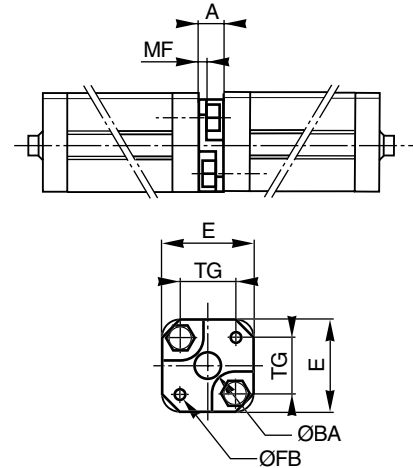

Cyl. bore mm	E mm	TG mm	ØFB mm	MF mm	A mm	ØBA mm
32	50	32,5	6,5	5	16	30
40	60	38,0	6,5	5	16	35
50	66	46,5	8,5	6	20	40
63	80	56,5	8,5	6	20	45
80	100	72,0	10,5	8	25	45
100	118	89,0	10,5	8	25	55



Cylinder mountings



Type	Description	Cyl. bore Ø mm	Mass kg	Order code
Swivel rod eye 	Swivel rod eye for articulated mounting of cylinder. Swivel rod eye can be combined with clevis bracket GA. Maintenance-free. Materials Swivel rod eye, nut: Galvanized steel Swivel bearing according to DIN 648K: Hardened steel	12	0,03	P1A-4DRS P1A-4DRS P1A-4HRS P1A-4JRS P1C-4KRS P1C-4LRS P1C-4MRS P1C-4MRS P1C-4PRS P1C-4PRS
		16	0,03	
		20	0,05	
		25	0,07	
		32	0,08	
		40	0,12	
		50	0,25	
		63	0,25	
		80	0,46	
		100	0,46	
		Stainless steel swivel rod eye 	Stainless-steel swivel rod eye for articulated mounting of cylinder. Swivel rod eye can be combined with clevis bracket GA. Maintenance-free. Materials Swivel rod eye: Stainless steel Swivel bearing according to DIN 648K: Stainless steel Use stainless steel nut (see page 25) with stainless steel swivel rod eye.	
16	0,03			
20	0,05			
25	0,08			
32	0,08			
40	0,12			
50	0,25			
63	0,25			
80	0,46			
100	0,46			

According to ISO 8139

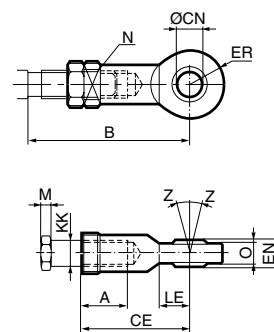
Cyl. bore mm	A mm	B min mm	B max mm	CE mm	CN H9 mm	EN h12 mm	ER mm	KK mm	LE min mm	M mm	N mm	O mm	Z mm
12	9	37	40	30	6	9	10	M6	10	3,2	10	6,8	10°
16	9	37	40	30	6	9	10	M6	10	3,2	10	6,8	10°
20	12	44	48	36	8	12	12	M8	12	4,0	13	9,0	12°
25	15	48	55	43	10	14	14	M10x1,25	14	5,0	17	10,5	12°
32	20	48	55	43	10	14	14	M10x1,25	15	5,0	17	10,5	12°
40	22	56	62	50	12	16	16	M12x1,25	17	6,0	19	12,0	12°
50	28	72	80	64	16	21	21	M16x1,5	22	8,0	22	15,0	15°
63	28	72	80	64	16	21	21	M16x1,5	22	8,0	22	15,0	15°
80	33	87	97	77	20	25	25	M20x1,5	26	10,0	32	18,0	15°
100	33	87	97	77	20	25	25	M20x1,5	26	10,0	32	18,0	15°



Cylinder mountings

Type	Description	Cyl. bore Ø mm	Mass kg	Order code
Clevis 	Clevis for articulated mounting of cylinder.	12	0,02	P1A-4DRC
		16	0,02	P1A-4DRC
	Material	20	0,05	P1A-4HRC
	Clevis, clip, nut: Galvanized steel	25	0,09	P1A-4JRC
	Pin: Hardened steel	32	0,09	P1C-4KRC
		40	0,15	P1C-4LRC
		50	0,35	P1C-4MRC
		63	0,35	P1C-4MRC
		80	0,75	P1C-4PRC
		100	0,75	P1C-4PRC
Stainless steel clevis 	Stainless-steel clevis for articulated mounting of cylinder.	12	0,02	P1S-4DRD
		16	0,02	P1S-4DRD
	Material	20	0,05	P1S-4HRD
	Clevis: Stainless steel	25	0,09	P1S-4JRD
	Pin: Stainless steel	32	0,09	P1S-4JRD
	Circlips according to DIN 471: Stainless steel	40	0,15	P1S-4LRD
		50	0,35	P1S-4MRD
	Use stainless steel nut (see page 25) with stainless steel swivel rod eye.	63	0,35	P1S-4MRD
		80	0,75	P1S-4PRD
		100	0,75	P1S-4PRD

According to ISO 8140

Cyl. bore mm	A mm	B min mm	B max mm	CE mm	CK h11/E9 mm	CL mm	CM mm	ER mm	KK mm	LE mm	M mm	O mm
12	12	28	34	24	6	12	6	7	M6	12	3,2	17,0
16	12	28	34	24	6	12	6	7	M6	12	3,2	17,0
20	16	37	44	32	8	16	8	10	M8	16	4,0	22,0
25	20	45	52	40	10	20	10	12	M10x1,25	20	5,0	28,0
32	20	45	52	40	10	20	10	16	M10x1,25	20	5,0	28,0
40	24	54	60	48	12	24	12	19	M12x1,25	24	6,0	32,0
50	32	72	80	64	16	32	16	25	M16x1,5	32	8,0	41,5
63	32	72	80	64	16	32	16	25	M16x1,5	32	8,0	41,5
80	40	90	100	80	20	40	20	32	M20x1,5	40	10,0	50,0
100	40	90	100	80	20	40	20	32	M20x1,5	40	10,0	50,0

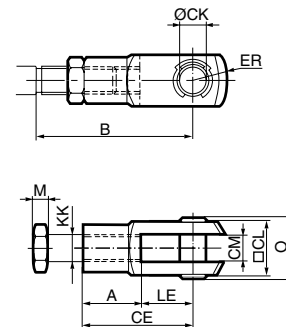

Cylinder mountings

Type	Description	Cyl. bore Ø mm	Mass kg	Order code
Flexocoupling	Flexocoupling for articulated mounting of piston rod. Flexocoupling is intended to take up axial angle errors within a range of $\pm 4^\circ$. Material Flexocoupling, nut: Galvanized steel Socket: Hardened steel	32	0,21	P1C-4KRF P1C-4LRF P1C-4MRF P1C-4MRF P1C-4PRF P1C-4PRF
		40	0,22	
		50	0,67	
		63	0,67	
		80	0,72	
		100	0,72	



Supplied complete with galvanized adjustment nut.

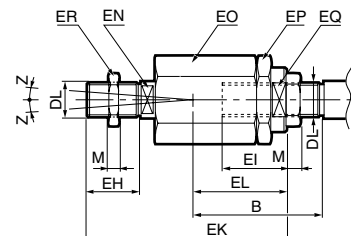

Cyl. bore mm	B min mm	B max mm	DL	EH	EI	EK	EL	EN	EO	EP	EQ	M	Z
32	36	43	M10x1,25	20	23	70	31	12	30	30	19	5	4°
40	37	43	M12x1,25	23	23	67	31	12	30	30	19	6	4°
50	53	61	M16x1,5	40	32	112	45	19	41	41	30	8	4°
63	53	61	M16x1,5	40	32	112	45	19	41	41	30	8	4°
80	57	67	M20x1,5	39	42	122	56	19	41	41	30	10	4°
100	57	67	M20x1,5	39	42	122	56	19	41	41	30	10	4°

Nut	Intended for fixed mounting of accessories to the piston rod.	12	0,002	0261210800
	Material: Galvanized steel (Cylinders supplied with galvanized nut)	16	0,002	0261210800
		20	0,005	0261211000
		25	0,007	9128985601
		32	0,007	9128985601
		40	0,010	0261109910
		50	0,021	9128985603
		63	0,021	9128985603
		80	0,040	0261109911
		100	0,040	0261109911

Stainless steel nut	Intended for fixed mounting of accessories to the piston rod.	12	0,002	9127385122
	Material: Stainless steel A2	16	0,002	9127385122
		20	0,005	9127385123
		25	0,007	9126725404
		32	0,007	9126725404
		40	0,010	9126725405
		50	0,021	9126725406
		63	0,021	9126725406
		80	0,040	0261109921
		100	0,040	0261109921

According to DIN 439 B

Cyl. bore mm	d	M	S
12	M6	3,2	10
16	M6	3,2	10
20	M8	4,0	13
25	M10x1,25	5,0	17
32	M10x1,25	5,0	17
40	M12x1,25	6,0	19
50	M16x1,5	8,0	24
63	M16x1,5	8,0	24
80	M20x1,5	10,0	30
100	M20x1,5	10,0	30

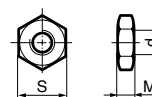

Our global series of sensors

This series of sensors is already being used or will be used in all future ranges in our global product programme involving cylinders/actuators. The sensors have small installation dimensions and either fit into the groove in the case profile or, as shown here, are fastened to the cylinder using a special attachment.

You can choose from electronic or reed sensors with a range of cable lengths fitted with 8 mm or M12 terminals.



Electronic sensors

The new electronic sensors are "Solid State", i.e. they have no moving parts at all. They are provided with short-circuit protection and transient protection as standard. The built-in electronics make the sensors suitable for applications with high on and off switching frequency, and where very long service life is required.

Technical data

Design	GMR (Giant Magnetic Resistance) magneto-resistive function
Installation	Sensor mounting P8S-TMC01
Outputs	PNP, normally open (also available in NPN design, normally closed, on request)
Voltage range	10-30 VDC 10-18 V DC, ATEX sensor
Ripple	max 10%
Voltage drop	max 2,5 V
Load current	max 100 mA
Internal consumption	max 10 mA
Actuating distance	min 9 mm
Hysteresis	max 1,5 mm
Repeatability accuracy	max 0,2 mm
On/off switching frequency	max 5 kHz
On switching time	max 2 ms
Off switching time	max 2 ms
Encapsulation	IP 67 (EN 60529)
Temperature range	-25 °C to +75 °C -20 °C to +45 °C, ATEX sensor
Indication	LED, yellow
Material housing	PA 12
Material screw	Stainless steel
Cable	PVC or PUR 3x0.25 mm ² see order code respectively

Reed sensors

The sensors are based on proven reed switches, which offer reliable function in many applications. Simple installation, a protected position on the cylinder and clear LED indication are important advantages of this range of sensors.

Technical data

Design	Reed element
Mounting	Sensor mounting P8S-TMC01
Output	Normally open , or normally closed
Voltage range	10-30 V AC/DC or 10-120 V AC/DC 24-230 V AC/DC
Load current	max 500 mA for 10-30 V or max 100 mA for 10-120 V max 30 mA for 24-230 V
Breaking power (resistive)	max 6 W/VA
Actuating distance	min 9 mm
Hysteresis	max 1,5 mm
Repeatability accuracy	0,2 mm
On/off switching frequency	max 400 Hz
On switching time	max 1,5 ms
Off switching time	max 0,5 ms
Encapsulation	IP 67 (EN 60529)
Temperature range	-25 °C to +75 °C
Indication	LED, yellow
Material housing	PA12
Material screw	Stainless steel
Cable	PVC or PUR 3x0.14 mm ² see order code respectively

Electronic sensors

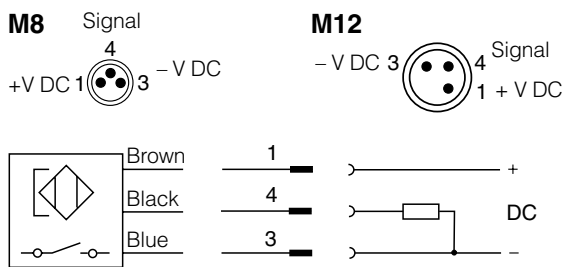

Reed sensors

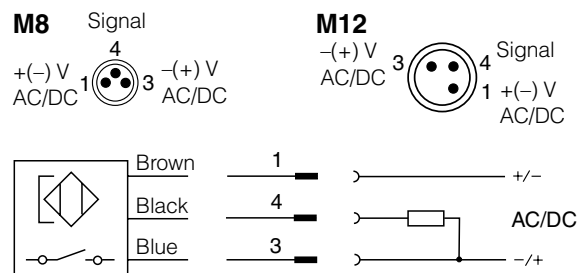

P8S-GCFPX

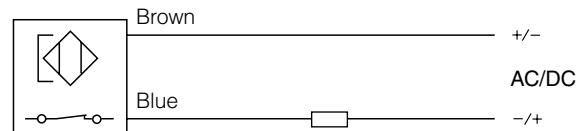

P8S-GRFLX / P8S-GRFLX2

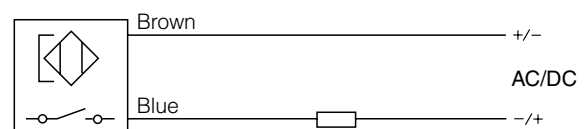

Dimensions

Sensors

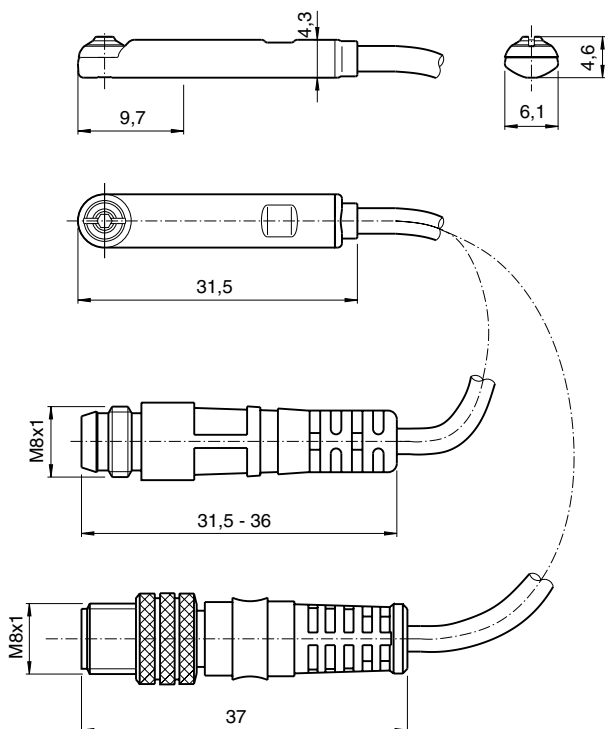

Ordering data

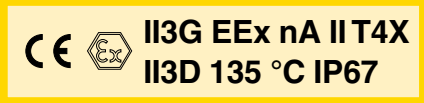
Output/function	Cable/connector	Weight kg	Order code
Electronic sensors , 10-30 V AC/DC			
PNP type, normally open	0,27 m PUR-cable and 8 mm snap-in male connector	0,007	P8S-GPSHX
PNP type, normally open	1,0 m PUR-cable and 8 mm snap-in male connector	0,013	P8S-GPSCX
PNP type, normally open	1,0 m PUR-cable and M8 screw male connector	0,013	P8S-GPCCX
PNP type, normally open	0,27 m PUR-cable and M12 screw male connector	0,015	P8S-GPMHX
PNP type, normally open	3 m PVC-cable without connector	0,030	P8S-GPFLX
PNP type, normally open	10 m PVC-cable without connector	0,110	P8S-GPFTX
Electronic sensor 18-30 V DC ATEX-certified			
			
Type PNP , normally open	3 m PVC-cable without connector	0,030	P8S-GPFLX/EX
Reed sensors , 10-30 V AC/DC			
Normally open	0,27 m PUR-cable and 8 mm snap-in male connector	0,007	P8S-GSSHX
Normally open	1,0 m PUR-cable and 8 mm snap-in male connector	0,013	P8S-GSSCX
Normally open	1,0 m PUR-cable and M8 male connector	0,013	P8S-GSCCX
Normally open	0,27 m PUR-cable and M12 screw male connector	0,015	P8S-GSMHX
Normally open	1,0 m PUR-cable and M12 screw male connector	0,023	P8S-GSMCX
Normally open	3 m PVC-cable without connector	0,030	P8S-GSFLX
Normally open	10 m PVC-cable without connector	0,110	P8S-GSFTX
Normally closed	5m PVC-cable without connector ¹⁾	0,050	P8S-GCFPX
Reed sensors, 10-120 V AC/DC			
Normally open	3 m PVC-cable without connector	0,030	P8S-GRFLX
Reed sensorer, 24-230 V AC/DC			
Normalt öppen	3 m PVC-kabel utan kontakt ¹⁾	0,030	P8S-GRFLX2

1) Without LED

Sensors for special applications

Sensors for applications where the short installation length and the 90 degree cable outlet are important factors. This type of sensor is a good alternative if a cylinder has a short stroke or tight installation.

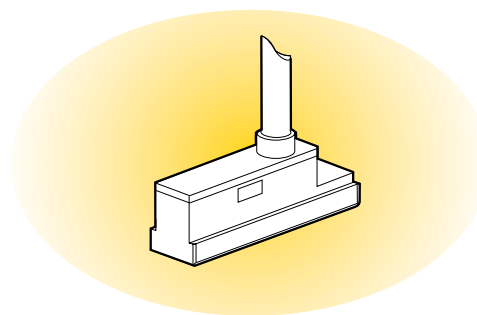

Reed switch sensors

The reed switch sensors incorporate a well-proven, universal-voltage, compact reed switch element, making them suitable for a wide range of applications. They can work with electronic control systems or conventional relay systems. No environment is too severe.

Technical data

Design	Reed
Output	Making
Voltage range	10 to 120 VAC/VDC
Max permissible ripple	10%
Max voltage drop	3 V
Max load current	100 mA
Max breaking power (resistive)	10 W
Min actuating distance	5 mm
Hysteresis	≤1,0 mm
Repeatability accuracy	≤0,2 mm
Max on/off switching frequency	400 Hz
Max on/off switching time	1 ms
Encapsulation	IP 67
Temperature range	-25 °C to +75 °C
Indication	LED, yellow
Shock resistance	30 g
Material, housing	PA 12
Material, mould	Epoxy
Cable	PVC 3x0,14 mm ²
Cable incl. female part connector	PVC 3x0,14 mm ²
Mounting	T slot

Electronic sensors

These sensors are of solid-state type, with no moving parts. Short-circuit and transient protection is incorporated as standard. The integral electronics make these sensors suitable for applications with very high switching frequencies.

Technical data

Design	Hall element
Output	PNP resp. NPN, N.O.
Voltage range	10-30 VDC
Max permissible ripple	10%
Max voltage drop	≤2 V
Max load current	150 mA
Max breaking power (resistive)	6 W
Internal consumption	15 mA
Min actuating distance	5 mm
Hysteresis	≤1,5 mm
Repeatability accuracy	≤0,2 mm
Max on/off switching frequency	50 Hz
P8S-SPELXD, SPETXD, SPTHXD	5 kHz
Others	0,8/3,0 ms
Max on/off switching time	IP 67
Encapsulation	-25 °C to +75 °C
Temperature range	LED, yellow
Indication	30 g
Shock resistance	PA 12
Material, housing	Epoxy
Material, mould	PVC 3x0,14 mm ²
Cable	PVC 3x0,14 mm ²
Cable incl. female part connector	Diam. 8 mm snap on
Connector	T slot
Mounting	

Ordering data

Output	Cable connection	Cable length	Weight kg	Order code
Reed sensors				
making	90°	3,0 m	0,030	P8S-SRELX
making	90°	10,0 m	0,110	P8S-SRETX
making	90°	0,3 m*	0,005	P8S-SRTHX

*) Cable shall be ordered separately.

Ordering data

Output	Cable connection	Cable length	Weight kg	Order code
Electronic sensors				
PNP, N.O.	90°	3,0 m	0,030	P8S-SPELXD
PNP, N.O.	90°	10,0 m	0,110	P8S-SPETXD
PNP, N.O.	90°	0,3 m*	0,005	P8S-SPTHXD

Dimensions

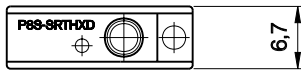
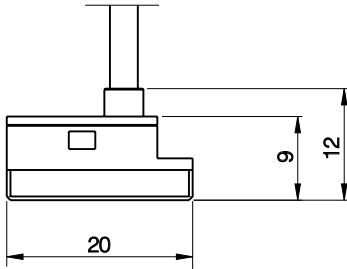
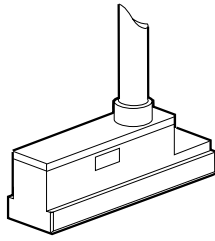

Reed sensor symbol

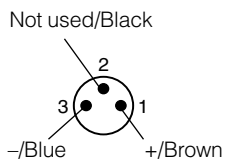
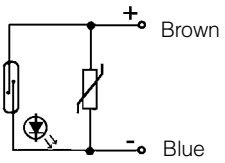

Electronic sensor symbol

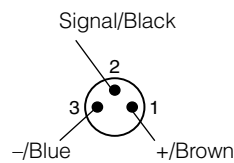
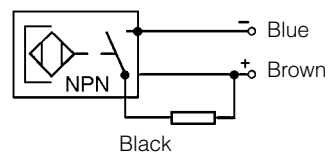
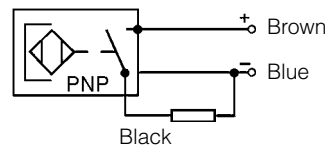

Connecting cables with one connector

The cables have an integral snap-in female connector.



Type of cable	Cable/connector	Weight kg	Order code
Cables for sensors, complete with one female connector			
Cable, Flex PVC	3 m, 8 mm Snap-in connector	0,07	9126344341
Cable, Flex PVC	10 m, 8 mm Snap-in connector	0,21	9126344342
Cable, Super Flex PVC	3 m, 8 mm Snap-in connector	0,07	9126344343
Cable, Super Flex PVC	10 m, 8 mm Snap-in connector	0,21	9126344344
Cable, Polyurethane	3 m, 8 mm Snap-in connector	0,01	9126344345
Cable, Polyurethane	10 m, 8 mm Snap-in connector	0,20	9126344346
Cable, Polyurethane	5 m, M12 screw connector	0,07	9126344348
Cable, Polyurethane	10 m, M12 screw connector	0,20	9126344349

Male connectors for connecting cables

Cable connectors for producing your own connecting cables. The connectors can be quickly attached to the cable without special tools. Only the outer sheath of the cable is removed. The connectors are available for M8 and M12 screw connectors and meet protection class IP 65.



Connector	Weight kg	Order code
M8 screw connector	0,017	P8SCS0803J
M12 screw connector	0,022	P8SCS1204J

Ready to use connecting cables with connectors at each end

As accessories the system comprises a large number of different cables in order to meet all requirements that may arise and to make the installation simple, fast and reliable.

Cables with moulded 8 mm snap-in round contacts in both ends. The cables are available in two types, one with a straight male and female connectors respectively, and one with a straight 3-pole male connector in one end and an angled 3-pole female connector in the other end.



Technical data

Contacts

Moulded 8 mm snap-in male/female contacts.
Enclosure IP67

Cable

Conductor 3x0,25 mm² (32x0,10 mm²)
Sheath PVC/PUR
Colour Black

Cables with straight 3-pole male and female connectors respectively.

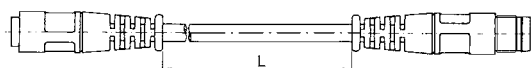

Cables with a straight 3-pole male connector in one end and an angled 3-pole female connector in the other end.

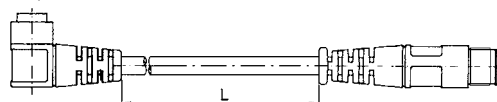

Designation	Weight kg	Order code
Cable with straight contacts, 0,2 m	0,02	9121717014
Cable with straight contacts, 0,3 m	0,02	9121717015
Cable with straight contacts, 0,5 m	0,03	9121717016
Cable with straight contacts, 1,0 m	0,03	9121717017
Cable with straight contacts, 2,0 m	0,05	9121717018
Cable with straight contacts, 3,0 m	0,07	9121717019
Cable with straight contacts, 5,0 m	0,12	9121717020
Cable with straight contacts, 10 m	0,23	9121717021

Designation	Weight kg	Order code
Cable with straight and angled connectors, 0,2 m	0,02	9121717022
Cable with straight and angled connectors, 0,3 m	0,02	9121717023
Cable with straight and angled connectors, 0,5 m	0,03	9121717024
Cable with straight and angled connectors, 1,0 m	0,03	9121717025
Cable with straight and angled connectors, 2,0 m	0,05	9121717026
Cable with straight and angled connectors, 3,0 m	0,07	9121717027
Cable with straight and angled connectors, 5,0 m	0,12	9121717028
Cable with straight and angled connectors, 10 m	0,23	9121717029

Connection block Valvetronic 110

The Valvetronic 110 is a connection block that can be used for collecting signals from sensors at various points on a machine and connecting them to the control system via a multicore cable. Valvetronic 110 can also be used for central connection of the multi-core cable to the outputs of a control system, and can be laid to a machine where the output signals can be connected. The connection block has ten 8 mm snap-in circular connectors and a multi-core cable which is available in lengths of 3 or 10 m. The connections on the block are numbered from 1 to 10. Blanking plugs are available for unused connections, as labels for marking the connections of each block.



Technical data

Connections:

Ten 3-pole numbered 8 mm round snap-in female contacts

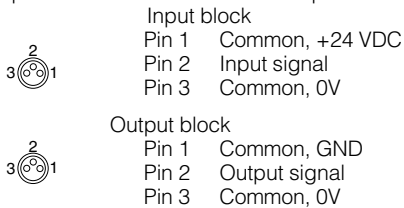

Electrical data:

Voltage 24 VDC (max. 60 V AC/75 V DC)
 Insulation group according to DIN 0110 class C
 Load max. 1 A per connection total max. 3 A

Cable:

Length 3 m or 10 m
 Type of cable LifYY11Y
 Conductor 12
 Area 0.34 mm²
 Colour marking According to DIN 47 100

Mechanical data

Enclosure IP 67, DIN 40050 with fitted contacts and/or blanking plugs.
 Temperature -20 °C to +70 °C





Material

Body PA 6,6 VD according to UL 94
 Contact holder PBTP
 Snap-in ring LDPE
 Moulding mass Epoxy
 Seal NBR
 Screws Plated steel

Industrial durability

Good chemical and oil resistance. Tests should be performed in aggressive environments.

Ordering data

Designation	Weight kg	Order code
 Connection block Valvetronic 110 with 3 m cable	0,32	9121719001
 Connection block Valvetronic 110 with 10 m cable	0,95	9121719002
 Blanking plugs (pack of 10) Use blanking plugs to close unused connections.	0,02	9121719003
 Labels (pack of 10) White labels to insert in grooves on the side of the connection	0,02	9121719004

Dimensions and wiring diagrams

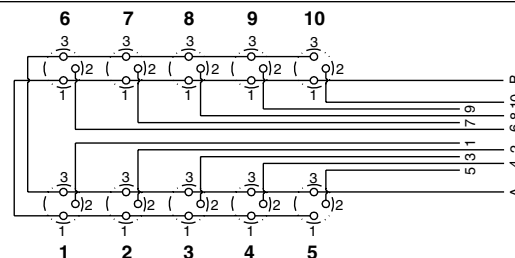
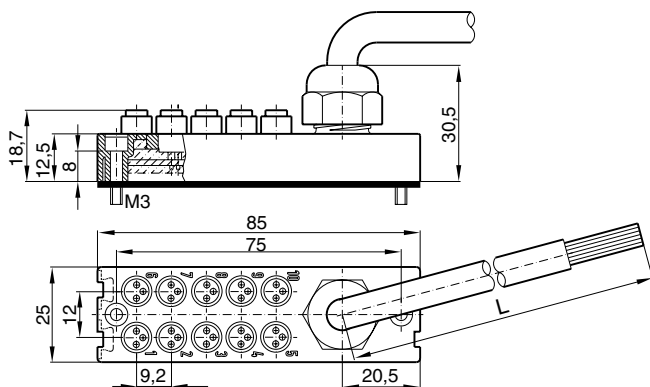

Conductor	Colour	Input	Output
1	Pink	Signal 1	Signal 1
2	Grey	Signal 2	Signal 2
3	Yellow	Signal 3	Signal 3
4	Green	Signal 4	Signal 4
5	White	Signal 5	Signal 5
6	Red	Signal 6	Signal 6
7	Black	Signal 7	Signal 7
8	Violet	Signal 8	Signal 8
9	Grey-Pink	Signal 9	Signal 9
10	Red-Blue	Signal 10	Signal 10
A	Blue	0 V	0 V
B	Brown	+24 V	PE

Seal kits for P1M

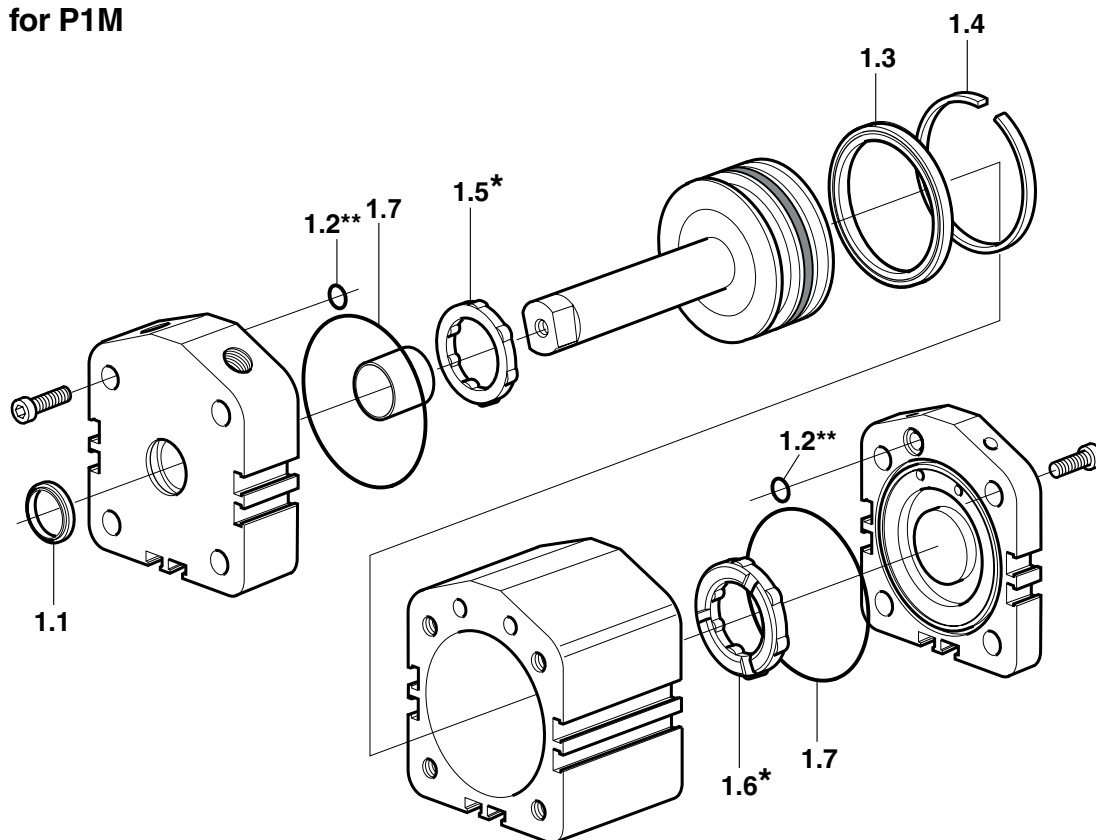

Seal kits for P1M

No	Qty	Part
1.1	1	Scraper ring/Piston rod seal
1.2	2	O-ring
1.3	1	Piston seals
1.4	1	Piston bearing
1.5	1	Front end bumper
1.6	1	Rear end bumper
1.7	2	O-ring

Material specification, see page 5

* Bumpers 1.5 and 1.6 not valid for high-temperature version, type G.

** Quantity and design vary, depending on the cylinder variant and model.

Seal kits for complete P1M cylinder

Cyl. bore mm	Option	
	Standard	High Temp
12	P1M-6DRN	P1M-6DRV
16	P1M-6FRN	P1M-6FRV
20	P1M-6HRN	P1M-6HRV
25	P1M-6JRN	P1M-6JRV
32	P1M-6KRN	P1M-6KRV
40	P1M-6LRN	P1M-6LRV
50	P1M-6MRN	P1M-6MRV
63	P1M-6NRN	P1M-6NRV
80	P1M-6PRN	P1M-6PRV
100	P1M-6QRN	P1M-6QRV

Grease for P1M



Weight g	Option	
	Standard	High Temp
30	9127394541	9127394521