



Air Motors

Series P1V-A

Catalogue 9127 0076-52 GB-ul



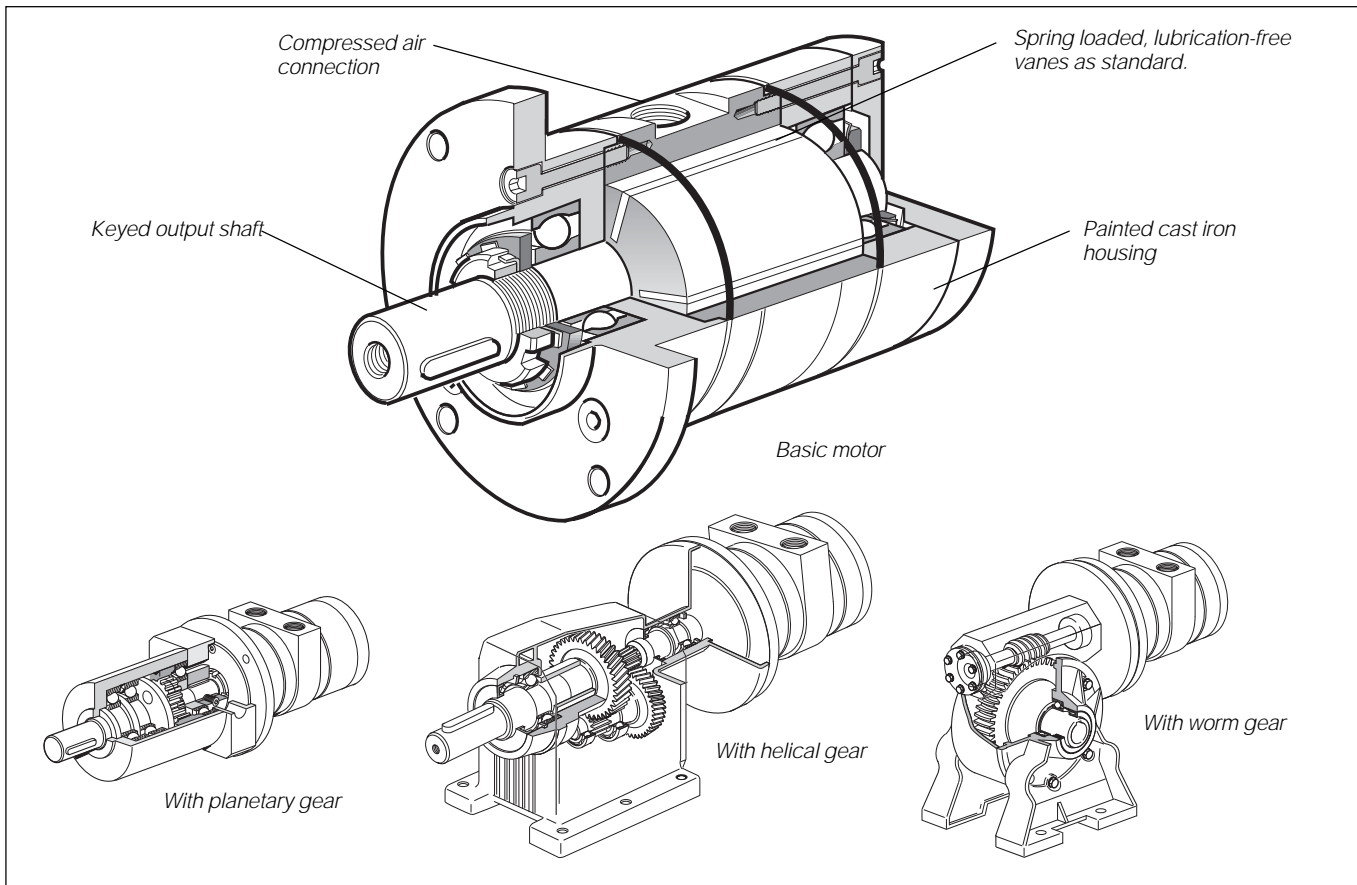

Air Motors, Series P1V-A

P1V-A is a range of reversible air motors intended for heavy and demanding applications. The motor housings are made from painted cast iron, and the components sealed to permit operation in damp and dirty environments.

The range contains three different sizes, P1V-A160, P1V-A260 and P1V-A360, with power ratings of 1600, 2600 or 3600 Watts. The basic motors can be supplied with built-in gearboxes, either planetary, helical or worm drive, to provide the correct speed of rotation and torque, and the correct installation mountings.

Basic motor

All pneumatic motors are equipped with spring loaded vanes as standard, which gives the motors very good starting and low speed running characteristics. They are also equipped with vanes for intermittent lube-free operation as standard. 100% lubrication-free vanes are obtainable as options. The simple construction of the motors makes them very reliable, with long service life and they are easy to service.

Motors with planetary gears

A P1V-A combined with a planetary gear has small installation dimensions, low weight in relation to performance, free installation position, flange mounting as standard, in line output shaft and high efficiency. They are available with shaft speeds ranging from 95 rpm to 1200 rpm, with torques ranging from 16 Nm to 160 Nm.

Motors with helical gears

A P1V-A combined with a helical gear has high efficiency, simple installation with flange or foot, and competitive pricing. They are available with shaft speeds ranging from 25 rpm to 1050 rpm, with torques ranging from 23 Nm to 1800 Nm. Oil-bath gears mean that the installation position must be decided beforehand. The installation position governs the amount of oil in the gear and the location of filling and drain plugs.

Motors with worm gears

A P1V-A combined with a worm drive gear has the following characteristics: gearboxes with high gear ratios are self-locking, which means that they can be used to maintain the output shaft in position, simple installation with the flange on the left or right sides or with a foot, small installation dimensions and competitive pricing. They are available with shaft speeds ranging from 62 rpm to 500 rpm, with torques ranging from 38 Nm to 670 Nm. Oil-bath gears mean that the installation position must be decided beforehand. The installation position governs the amount of oil in the gear and the location of filling and drain plugs.



Products specially designed for mobile applications

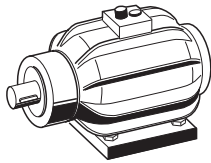

Air motors have much smaller installation dimensions than corresponding electric motors.



Air motors can be stopped and started continually without damage.

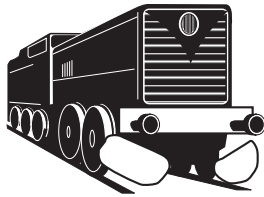

Air motors can be loaded until they stall, without damage. They are designed to be able to withstand the toughest heat, vibration, impact etc.

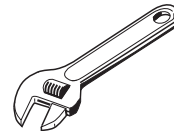

The simple design principle of air motors make them very easy to service.

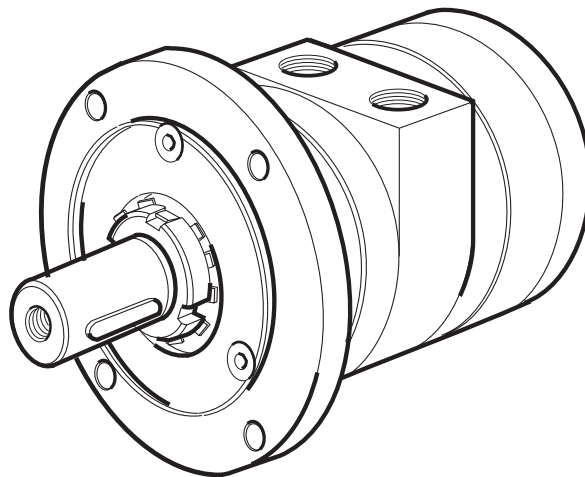

The weight of an air motor is several times less than corresponding electric motors.



The motors are reversible as standard.

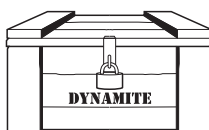

Air motors can be used in the harshest environments.



The reliability of air motors is very high, thanks to the design and the low number of moving parts.

Principles of air motor function

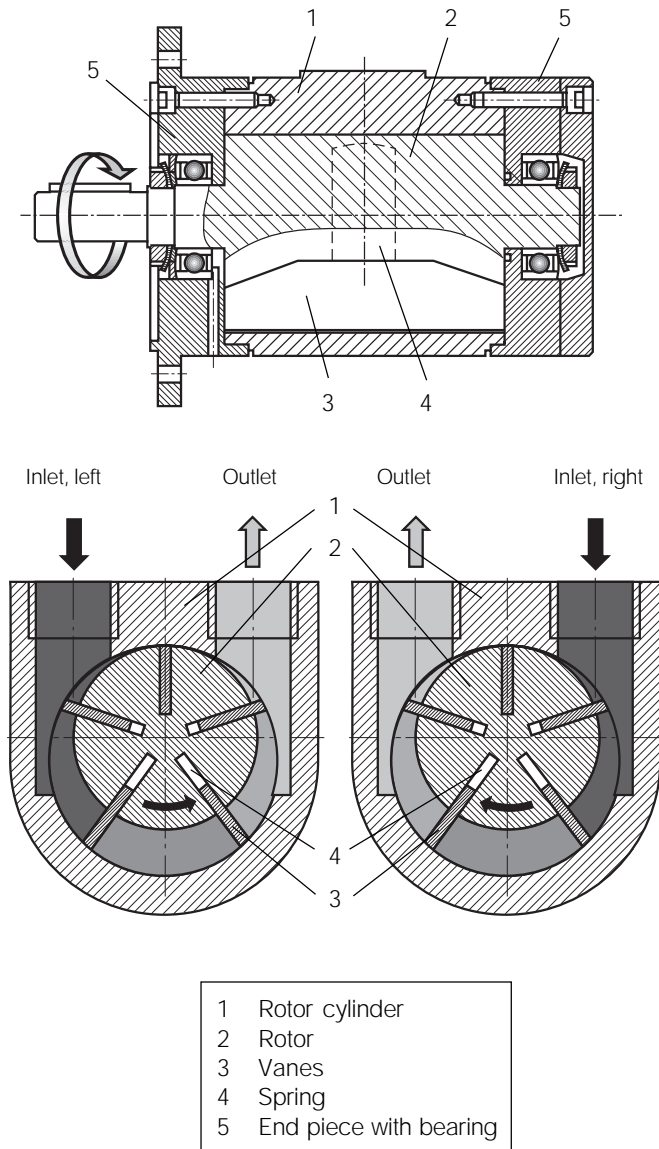

Torque and power graphs

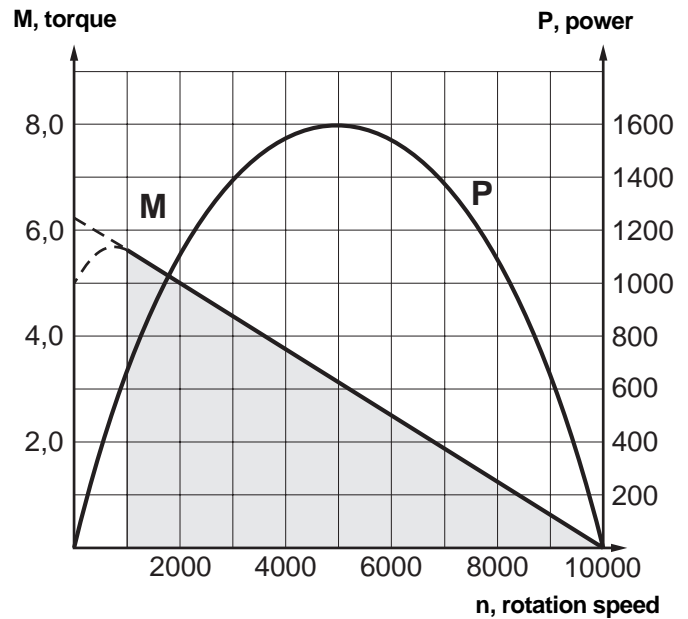

There is a graph for each motor, where torque and power can be read off as functions of speed. When the motor is stationary without air and when it rotates without load on the output spindle (free speed), it does not develop any power. Maximum power is normally developed when the motor is braked to half the free speed.

At the free speed, the specified torque is zero, but as soon as the motor is braked, the torque increases linearly until the motor stalls.

Since the motor can then stop with the vanes in various positions, it is not possible to specify an exact start torque, but a minimum start torque is specified in all tables.

There are a number of designs of an air motor. We have chosen to use the vane rotor design, however, because of its simple design and reliable operation. The small external dimensions of vane motors make them very easy to build into all applications.

The principle of the vane motor is that a rotor is provided with a number of vanes and is enclosed in a so-called rotor cylinder. The motor is supplied with compressed air through one connection and air escapes from the other connection. To give reliable starting, the springs press the vanes against the rotor cylinder. The air pressure always bears at right angles against a surface. This means that the torque of the motor is a result of the vane surfaces and the air pressure.

Correction diagrams

Correction factor

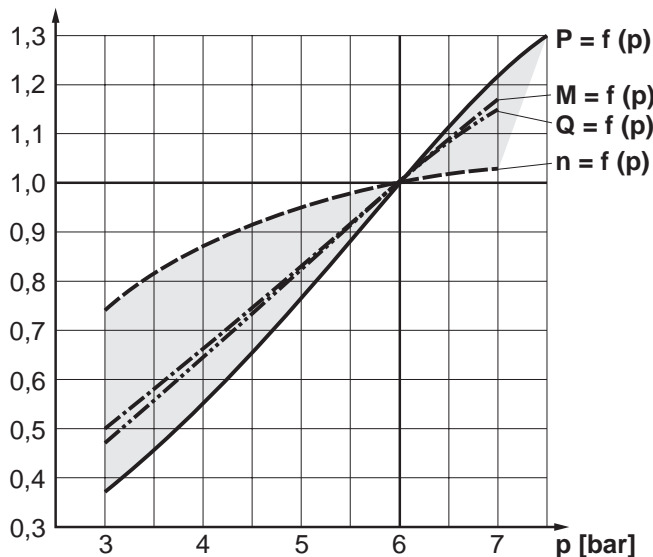

P = power
M = torque
Q = air consumption
n = speed

All catalogue data and curves are specified at a supply pressure of 6 bar to the motor. This diagram shows the effect of pressure on speed, specified torque, power and air consumption.

Start off on the curve at the pressure used and then look up to the lines for power, torque and air consumption. Read off the correction factor on the Y axis for each curve and multiply this by the specified catalogue data in the table, or data read from the torque and power graphs.

Example: at 4 bar supply pressure, the power is only 0.55 x power at 6 bar supply pressure.

This example shows how strongly power falls if supply pressure is reduced. You must therefore ensure that the motor is supplied through pipes of sufficient diameter to avoid pressure drop.

Speed regulation

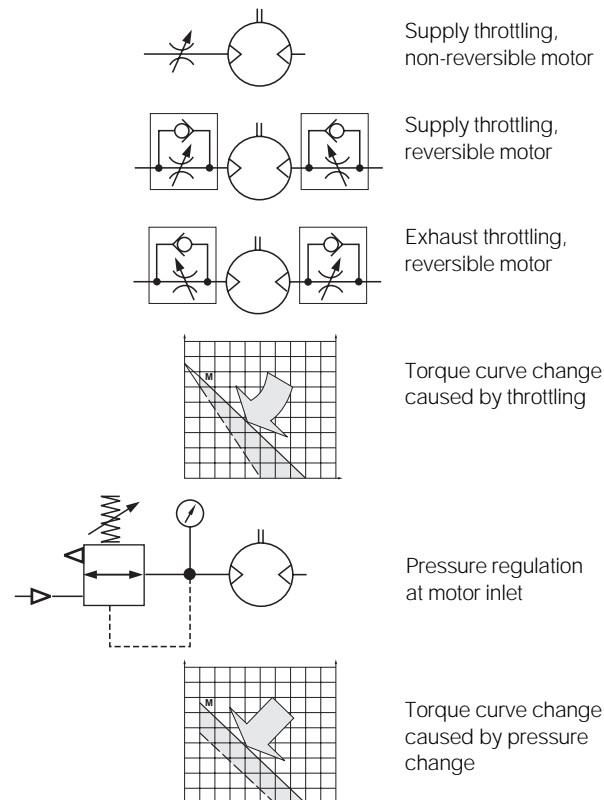

Throttling

The most common way to reduce the speed of a motor is to install a flow control valve in the air inlet. When the motor is used in applications where it must reverse and it is necessary to restrict the speed in both directions, flow control valves with by-pass should be used in both directions.

Inlet throttling

If the inlet air is restricted, the air supply is restricted and the free speed of the motor falls, but there is full pressure on the vanes at low speeds. This means that we get full torque from the motor at low speeds despite the low air flow.

Since the torque curve becomes "steeper", this also means that we get a lower torque at any given speed than would be developed at full air flow.

Pressure regulation

The speed and torque can also be regulated by installing a pressure regulator in the inlet pipe. This means that the motor is constantly supplied with air at lower pressure, which means that when the motor is braked, it develops a lower torque on the output shaft.

In brief: Inlet throttling gives reduced speed in one direction but maintains torque when braked. The torque curve becomes steeper. A restriction gives reduced speed but retains torque when braked. The torque curve becomes steeper. Pressure regulation in the inlet cuts torque when the motor is braked, and also reduced speed. The torque curve is moved parallel.

Direction of motor rotation

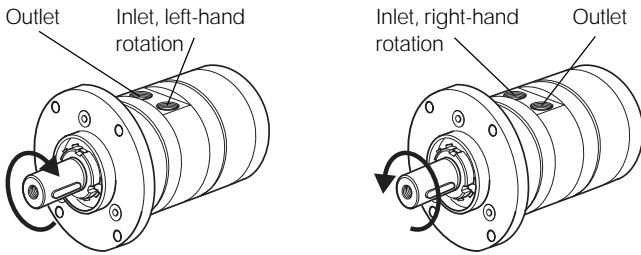

The direction of rotation of reversible motors is obtained by supplying inlet L or inlet R with compressed air. The motor can be stopped and started continually without damage occurring.

Air supply

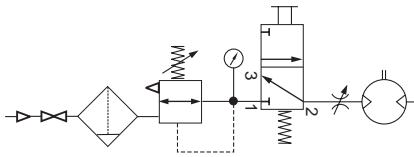

Shut-off, filtering, pressure regulation and control valve

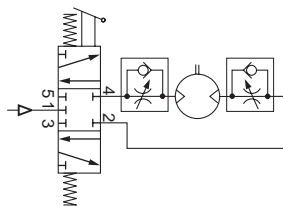

Reversible motor with 5/3 control valve

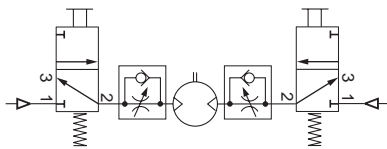

Reversible motor with two 3/2 control valves

The air with which the motor is supplied must be filtered and regulated. Directional valves are needed to provide it with air, to get the motor to rotate when we want it to. These valves can be equipped with several means of actuation, such as electric, manual and pneumatic control. When the motor is used in a non-reversible application, it is sufficient to use a 2/2 or 3/2 valve for supply. Either one 5/3 or two 3/2 valves are needed for a reversible motor, to ensure that the motor receives compressed air and the residual air outlet is vented. A flow control valve can be installed in the supply pipe to regulate the motor speed if the motor is not used as a reversible motor. One flow control valve with by-pass is needed to regulate each direction of rotation if the motor is used as a reversible motor. The built-in check valve will then allow air from the residual air outlet to escape through the outlet port in the control valve.

The compressed air supply must have sufficiently large pipes and valves to give the motor maximum power. The motor needs 6 bar at the supply port all the time. A reduction of pressure to 5 bar reduces the power developed to 77%, and to 55% at 4 bar.

Choice of components for air supply

Since the supply pressure at the air motor inlet port is of considerable importance for obtaining the power, speed and torque quoted in the catalogue, the recommendations below should be observed.

The following data must be complied with:

Supply pressure: 7 bar

Regulator pressure setting: 6.7 bar

Pipe length between air treatment unit and valve: max. 1 m

Pipe length valve and air motor: max. 2 m

The pressure drop through the air preparation unit, pipe, valve and pipe means that 6 bar pressure is obtained at the motor supply port.

Please refer to the correction diagram on page 7, which shows what lower supply pressure means for power, speed and torque.

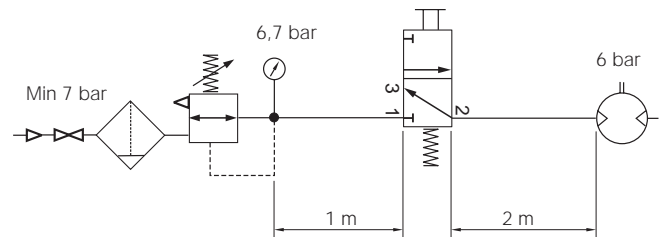

Air motor	P1V-A160	P1V-A260	P1V-A360
Air flow required, NI/s	32	60	80
Min pipe ID, inlet, mm	19	19	22
Min pipe ID, outlet, mm	19	25	32
Recommended air treatment unit			
Maxi Modular G1/2 and G3/4			
Recommended valve series			
Valves with connections in valve housing			
VE42/43			
VE82/83			
Valves with connections in base plate			
Apollo, size 3			
Flexflow VG45			
Flexflow VE45			

Silencing

Exhaust silencer

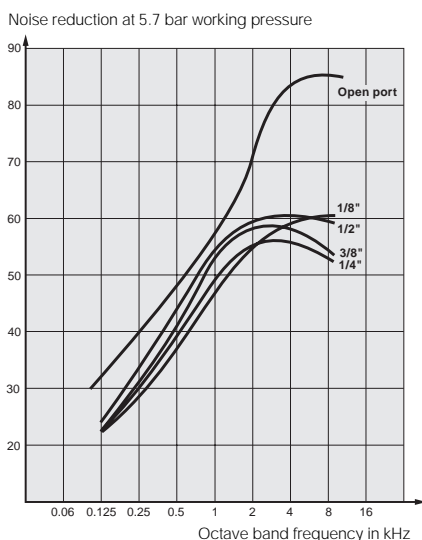
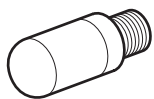

Central silencer

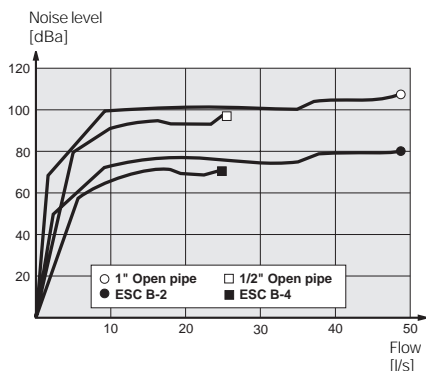
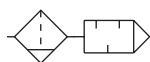
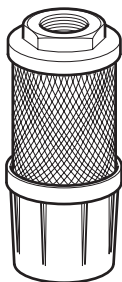

The noise from a air motor consists of both mechanical noise and a pulsating noise from the air flowing out of the outlet. The installation of the motor has a considerable effect on mechanical noise. It should be installed so that no mechanical resonance effects can occur. The outlet air creates a noise level which can amount to 115 dB(A) if the air is allowed to exhaust freely into the atmosphere. Various types of exhaust silencers are used to reduce this level. The most common type screws directly onto the exhaust port of the motor. Since the motor function causes the exhaust air to pulsate, it is a good idea to allow the air to exhaust into some kind of chamber first, which reduces the pulsations before they reach the silencer. The device which gives best silencing is to connect a soft plastic hose to a large central silencer which has the largest possible area, to reduce the speed of the out-flowing air as far as possible.

NOTE! Remember that a silencer which is too small or is blocked, generates back pressure on the outlet side of the motor, which reduces the motor power.

Lubrication and service life



Oil and oil mist are things which one tries to avoid to get the best possible working environment. In addition, purchasing, installation and maintenance of oil mist equipment costs money and, above all, time to achieve optimum lubrication effect. Users in all industries now try to avoid using components which have to be lubricated.

The P1V-A motor is equipped with vanes for intermittent operation as standard, which is the most common application of air motors. The motor is also available with optional hard vanes for continuous lubrication-free operation (option "C").

Expected service life of P1V-A motors

Air treatment

Filtering	40 µm or better
Dew point	+3 to +4 °C
Air temperature	+20°C

Intermittent lubrication-free operation of P1V-A standard motors

Duty cycle	70%
Max. duration of intermittent use	15 minutes
Filtering 40 µm	app. 750 hours operation
Filtering 5 µm	app. 1,000 hours operation

Continuous operation of P1V-A standard motors, with lubrication

Oil volume	1 drop oil/Nm ³
Filtering 40 µm	app. 1,000 hours operation
Filtering 5 µm	app. 2,000 hours operation

Continuous lubrication-free operation of P1V-A motors equipped with hard vanes (option "C")

Filtering 40 µm	app. 750 hours operation
Filtering 5 µm	app. 1,000 hours operation

Please refer to page 39 for service kits.

Choice of air motor, general

The motor to be used should be selected by starting with the torque needed at a specific spindle speed. In other words, to choose the right motor, you have to know the required speed and torque. Since maximum power is reached at half the motor's free speed, the motor should be chosen so that the point aimed at is as close as possible to the maximum power of the motor.

The design principle of the motor means that higher torque is generated when it is braked, which tends to increase the speed, etc. This means that the motor has a kind of speed self-regulation function built in.

Use the following graph to choose the correct motor size and the correct type of gear as appropriate. The graph contains the points for the maximum torque of each motor at maximum power. Put in your point on the graph and select a marked point above and to the right of the point you need.

Then check the characteristic graph of each motor to find more accurate technical data. Always select a motor where the data required is in the grey field. Also use the correction diagram to see what it would mean to use different air supply pressures with the motor.

Tip: Select a motor which is slightly too fast and powerful, regulate its speed and torque with a pressure regulator and/or restriction to achieve the optimum working point.

Choice of motors with planetary gears

Torque at maximum power (Nm)

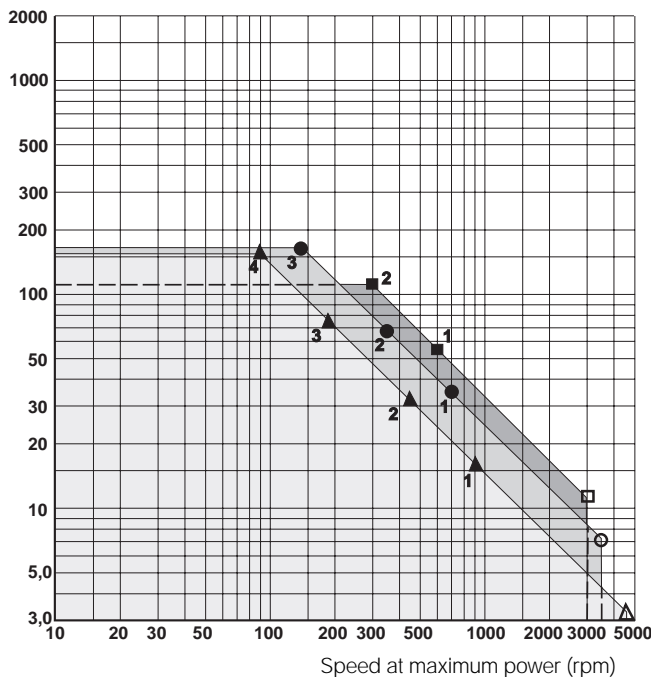

Planetary gears are characterised by high efficiency, low moment of inertia and can offer high gear ratios. The output shaft is always in the centre of the gearbox. Small installation dimensions relative to the torque provided. The gears are lubricated by grease, which means that it can be installed in all conceivable positions.

- Small installation dimensions
- Free installation position
- Simple flange installation
- Low weight
- Output shaft in centre
- High efficiency

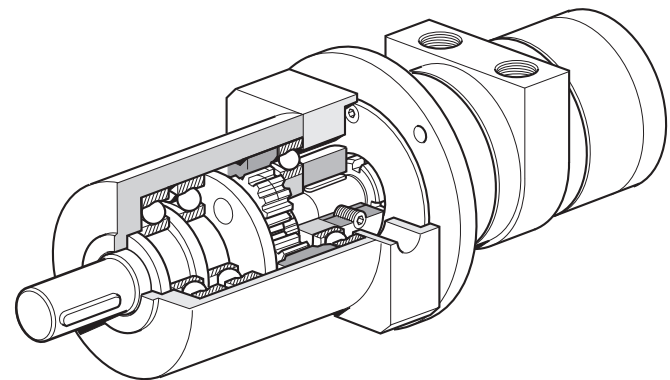

Air motors in diagram above

- △ P1V-A160A0900, please refer to page 15
- ▲ 1 P1V-A160B0120, please refer to page 16
- ▲ 2 P1V-A160B0060, please refer to page 16
- ▲ 3 P1V-A160B0019, please refer to page 16
- ▲ 4 P1V-A160B0010, please refer to page 16
- P1V-A260A0700, please refer to page 15
- 1 P1V-A260B0120, please refer to page 16
- 2 P1V-A260B0060, please refer to page 16
- 3 P1V-A260B0019, please refer to page 16
- P1V-A360A0600, please refer to page 15
- 1 P1V-A360B0096, please refer to page 16
- 2 P1V-A360B0048, please refer to page 16

Choice of motors with helical gears

Torque at maximum power (Nm)

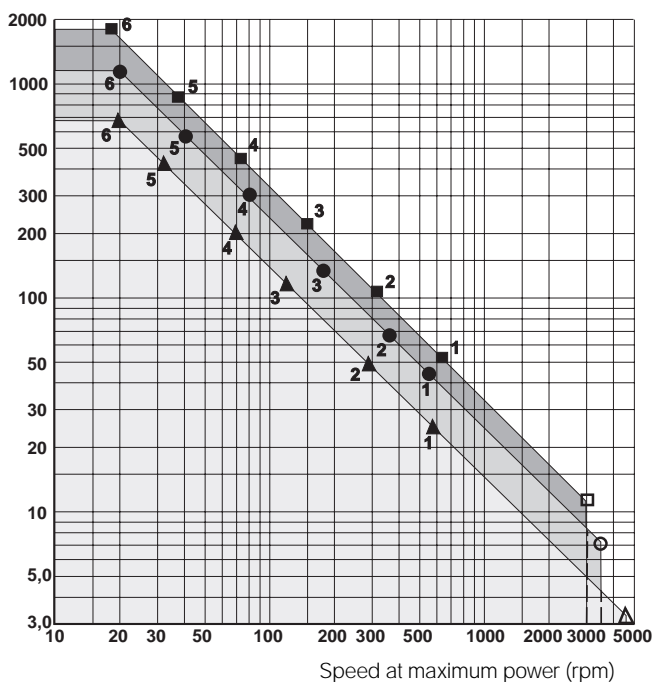

Helical gears are characterised by high efficiency. Several reduction stages permit relatively high gear ratios. Central output shaft and simple installation with flange or foot.

Oil-bath gearboxes mean that the installation position must be decided in advance. The installation position determines the volume of oil in the gearbox and location of oil filling and drain plugs.

- High efficiency
- Simple flange or foot installation
- Relatively low price
- Installation position must be chosen in advance
- Higher weight than planetary or worm drive gears.

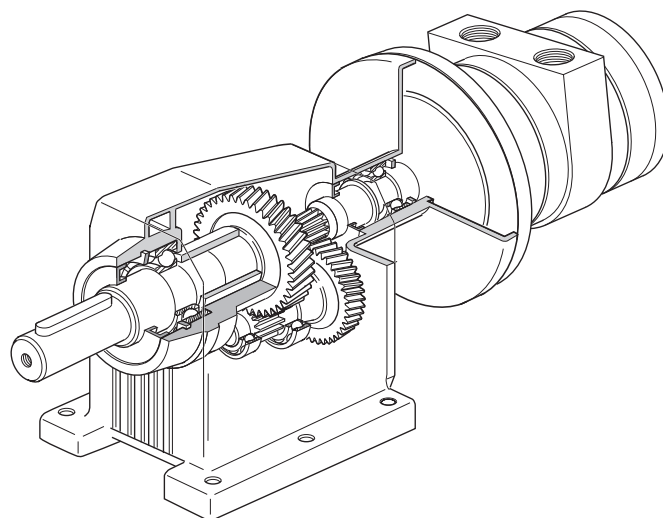

Air motors in diagram above

- △ P1V-A160A0900, please refer to page 15
- ▲ 1 P1V-A160•0066••, Choose installation below
- ▲ 2 P1V-A160•0032••, Choose installation below
- ▲ 3 P1V-A160•0014••, Choose installation below
- ▲ 4 P1V-A160•0008••, Choose installation below
- ▲ 5 P1V-A160•0004••, Choose installation below
- ▲ 6 P1V-A160•0003••, Choose installation below
- P1V-A260A0700, please refer to page 15
- 1 P1V-A260•0080••, Choose installation below
- 2 P1V-A260•0052••, Choose installation below
- 3 P1V-A260•0025••, Choose installation below
- 4 P1V-A260•0011••, Choose installation below
- 5 P1V-A260•0006••, Choose installation below
- 6 P1V-A260•0003••, Choose installation below
- P1V-A360A0600, please refer to page 15
- 1 P1V-A360•0105••, Choose installation below
- 2 P1V-A360•0052••, Choose installation below
- 3 P1V-A360•0025••, Choose installation below
- 4 P1V-A360•0013••, Choose installation below
- 5 P1V-A360•0006••, Choose installation below
- 6 P1V-A360•0003••, Choose installation below

Installation, flange mounting

Please refer to page 18

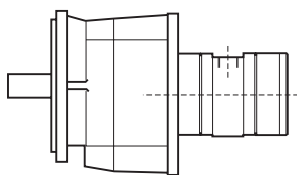

Installation, foot mounting

Please refer to page 19

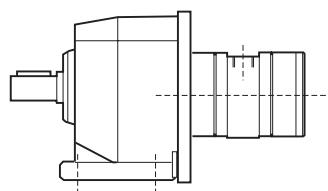

Choice of motors with worm gears

Torque at maximum power (Nm)

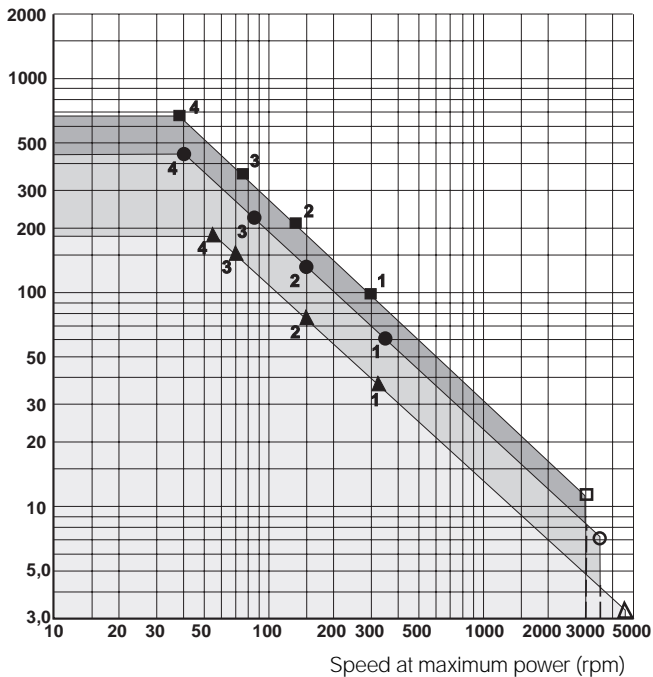

Worm gears are characterised by relatively simple technical construction, with a worm and pinion. This can give a large gear ratio and small dimensions. The efficiency of a worm drive gear is considerably lower than for planetary or helical gears. The design principle of worm drive gears makes them self-locking at higher gear ratios (the output shaft is "locked").

The output shaft comes out at an angle of 90° to the motor spindle. Installation is simple, with a flange on the left or right side, or with a foot. The gearbox is equipped as standard with a hollow output shaft with a key slot. Loose shafts with key can put the output shaft on the right, left, or on both sides.

Oil-bath gearboxes mean that the installation position must be decided in advance. The installation position determines the volume of oil in the gearbox and location of oil filling and drain plugs.

- Low weight in relation to gear ratio
- Non-reversible at high gear ratios
- Relatively low price
- Relatively low efficiency
- Installation position must be decided in advance
- Output shaft at 90° to motor spindle

Installation, flange mounting, left-hand

Please refer to page 22

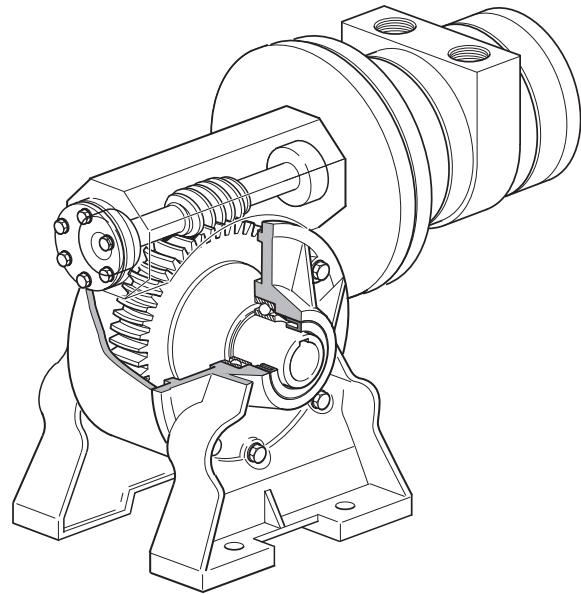
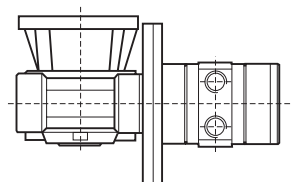

Air motors in diagram above

- △ P1V-A160A0900, please refer to page 15
- ▲ 1 P1V-A160•0043••, Choose installation below
- ▲ 2 P1V-A160•0020••, Choose installation below
- ▲ 3 P1V-A160•0010••, Choose installation below
- ▲ 4 P1V-A160•0008••, Choose installation below
- P1V-A260A0700, please refer to page 15
- 1 P1V-A260•0050••, Choose installation below
- 2 P1V-A260•0022••, Choose installation below
- 3 P1V-A260•0013••, Choose installation below
- 4 P1V-A260•0008••, Choose installation below
- P1V-A360A0600, please refer to page 15
- 1 P1V-A360•0050••, Choose installation below
- 2 P1V-A360•0022••, Choose installation below
- 3 P1V-A360•0013••, Choose installation below
- 4 P1V-A360•0006••, Choose installation below

Installation, foot mounting

Please refer to page 24

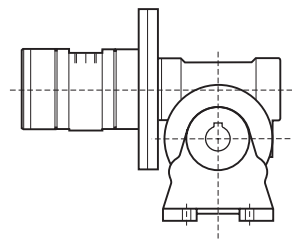

Installation, flange mounting, right-hand

Please refer to page 23

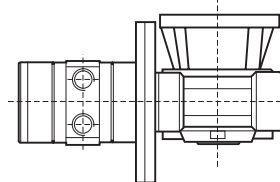

Technical data

Working pressure	Max 7 bar
Working temperature	-30 °C to +100 °C
Medium	40 µm filtered air with or without oil mist

Design data**Basic motor**

- Robust design with few components
- Spring loaded vanes as standard give good starting and low speed characteristics
- Keyed output shaft
- Reversible operation

Planetary gear

- Precision made gears with efficiency over 95%
- Sealed, permanently grease lubrication gives free installation position
- Compact installation and low weight
- Central output shaft

Helical gear

- Two versions available, with flange or foot
- High efficiency, 90 to 95%
- Oil-bath gearboxes mean that the installation position must be decided in advance. The installation position determines the volume of oil in the gearbox and location of oil filling and drain plugs.

Worm gear

- Available in three versions, for installation with left-hand flange, right-hand flange or foot mounting.
- Compact size and low weight
- Self-locking in higher ratios
- Output shaft at 90° angle to motor spindle
- Hollow output shaft with key slot. Single-ended or "through" twin shaft as options.
- Oil-bath gearboxes mean that the installation position must be decided in advance. The installation position determines the volume of oil in the gearbox and location of oil filling and drain plugs.

Table and diagram data

All values are typical values, with a tolerance of $\pm 10\%$

Options

Other variants on request.

Material specification**Basic motor**

Housing	Cast iron, synthetic paint, black
Spindle, rotor	High grade steel
Key	Hardened steel
O-rings	Nitrile rubber, NBR
Screws	Zinc-coated steel

Planetary gear

Housing	Alloy steel, synthetic paint, black
Shaft	High grade steel
Key	Hardened steel
Shaft seals	Nitrile rubber, NBR
Screws	Zinc-coated steel

Helical gear

Housing	Aluminium or cast iron, synthetic paint, black
Shaft	High grade steel
Key	Hardened steel
Shaft seals	Nitrile rubber, NBR
Screws	Zinc-coated steel

Worm drive gear

Housing	Aluminium or cast iron, synthetic paint, black
Shaft	High grade steel
Key	Hardened steel
Pinion	Chill cast phosphor bronze
Worm	Alloyed, hardened steel
Shaft seals	Nitrile rubber, NBR
Screws	Zinc-coated steel

Accessories

Keyed shafts for worm gear	
Shaft	High grade steel
Key	Hardened steel

Order key

P1V-A	160	E	0	066	B6																																																						
<table border="1" style="width: 100%; border-collapse: collapse;"> <tr><th colspan="2">Motor size</th></tr> <tr><td style="text-align: center;">160</td><td>1600 W</td></tr> <tr><td style="text-align: center;">260</td><td>2600 W</td></tr> <tr><td style="text-align: center;">360</td><td>3600 W</td></tr> </table>	Motor size		160	1600 W	260	2600 W	360	3600 W	<table border="1" style="width: 100%; border-collapse: collapse;"> <tr><th colspan="2">Function</th></tr> <tr><td style="text-align: center;">A</td><td>Basic motor without gear-box, keyed shaft</td></tr> <tr><td style="text-align: center;">B</td><td>With planetary gear, keyed shaft</td></tr> <tr><td style="text-align: center;">D</td><td>With helical gear, flange, keyed shaft</td></tr> <tr><td style="text-align: center;">E</td><td>With helical gear, foot, keyed shaft</td></tr> <tr><td style="text-align: center;">F</td><td>With worm gear, flange left, hollow shaft with key slot</td></tr> <tr><td style="text-align: center;">G</td><td>With worm gear, flange right, hollow shaft with key slot</td></tr> <tr><td style="text-align: center;">H</td><td>With worm gear, foot, hollow shaft with key slot</td></tr> </table>	Function		A	Basic motor without gear-box, keyed shaft	B	With planetary gear, keyed shaft	D	With helical gear, flange, keyed shaft	E	With helical gear, foot, keyed shaft	F	With worm gear, flange left, hollow shaft with key slot	G	With worm gear, flange right, hollow shaft with key slot	H	With worm gear, foot, hollow shaft with key slot	<table border="1" style="width: 100%; border-collapse: collapse;"> <tr><th colspan="2">Free/max speed per min</th></tr> <tr><td style="text-align: center;">000</td><td>0000</td></tr> <tr><td style="text-align: center;">900</td><td>9000</td></tr> </table>	Free/max speed per min		000	0000	900	9000	<table border="1" style="width: 100%; border-collapse: collapse;"> <tr><th colspan="2">Installation position</th></tr> <tr><td style="text-align: center;">-</td><td>Free installation</td></tr> <tr><th colspan="2">Horizontal installation</th></tr> <tr><td style="text-align: center;">B3</td><td>Installation position B3</td></tr> <tr><td style="text-align: center;">B5</td><td>Installation position B5</td></tr> <tr><td style="text-align: center;">B6</td><td>Installation position B6</td></tr> <tr><td style="text-align: center;">B7</td><td>Installation position B7</td></tr> <tr><td style="text-align: center;">B8</td><td>Installation position B8</td></tr> <tr><th colspan="2">Vertical installation</th></tr> <tr><td style="text-align: center;">V1</td><td>Installation position V1</td></tr> <tr><td style="text-align: center;">V3</td><td>Installation position V3</td></tr> <tr><td style="text-align: center;">V5</td><td>Installation position V5</td></tr> <tr><td style="text-align: center;">V6</td><td>Installation position V6</td></tr> </table>	Installation position		-	Free installation	Horizontal installation		B3	Installation position B3	B5	Installation position B5	B6	Installation position B6	B7	Installation position B7	B8	Installation position B8	Vertical installation		V1	Installation position V1	V3	Installation position V3	V5	Installation position V5	V6	Installation position V6
Motor size																																																											
160	1600 W																																																										
260	2600 W																																																										
360	3600 W																																																										
Function																																																											
A	Basic motor without gear-box, keyed shaft																																																										
B	With planetary gear, keyed shaft																																																										
D	With helical gear, flange, keyed shaft																																																										
E	With helical gear, foot, keyed shaft																																																										
F	With worm gear, flange left, hollow shaft with key slot																																																										
G	With worm gear, flange right, hollow shaft with key slot																																																										
H	With worm gear, foot, hollow shaft with key slot																																																										
Free/max speed per min																																																											
000	0000																																																										
900	9000																																																										
Installation position																																																											
-	Free installation																																																										
Horizontal installation																																																											
B3	Installation position B3																																																										
B5	Installation position B5																																																										
B6	Installation position B6																																																										
B7	Installation position B7																																																										
B8	Installation position B8																																																										
Vertical installation																																																											
V1	Installation position V1																																																										
V3	Installation position V3																																																										
V5	Installation position V5																																																										
V6	Installation position V6																																																										
<table border="1" style="width: 100%; border-collapse: collapse;"> <tr><th colspan="2">Air motor family</th></tr> <tr><td style="text-align: center;">P1V-A</td><td>Large vane motor, reversible</td></tr> </table>	Air motor family		P1V-A	Large vane motor, reversible																																																							
Air motor family																																																											
P1V-A	Large vane motor, reversible																																																										
<p>Possible combinations Please refer to pages 15 to 24</p>																																																											

A: Free installation positions, basic motor

Please refer to page 15

B: Free installation positions, planetary gear

Please refer to page 16

D: Free installation positions, helical gear and flange

Please refer to page 18

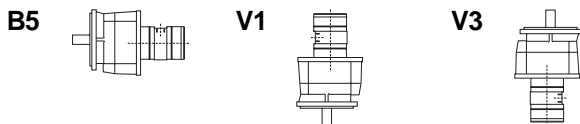

F: Installation pos., worm gear and flange, left-hand

Please refer to page 22

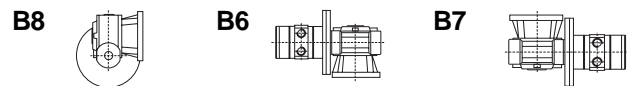
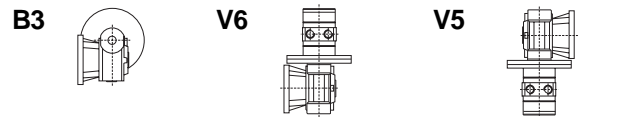

G: Installation pos., worm gear and flange, right-hand

Please refer to page 23

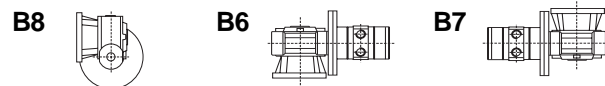
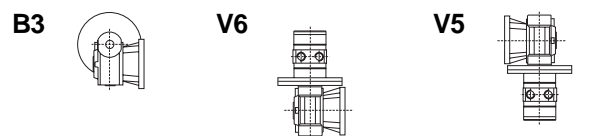

E: Installation positions, helical gear and foot

Please refer to page 19

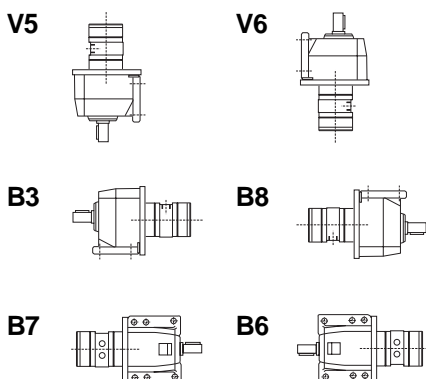

H: Installation positions, worm gear and foot

Please refer to page 24

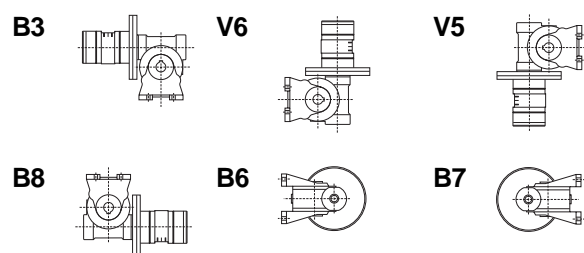

NOTE! All technical data are based on a working pressure of 6 bar.

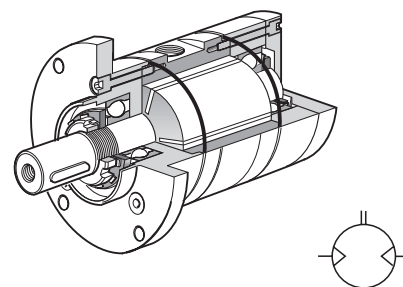

A: Basic motor with keyed shaft

Max power	Free speed*	Speed at max power	Torque at max power	Min start torque	Air consumption at max power	Con-nection	Min pipe ID inlet/outlet	Weight	Order code
kW	rpm	rpm	Nm	Nm	l/s		mm	Kg	
Series P1V-A160									
1,600	9000	4500	3,3	5,0	32	G1/2	19/19	4,2	P1V-A160A0900
Series P1V-A260									
2,600	7000	3500	7,1	11,0	60	G3/4	19/25	7,9	P1V-A260A0700
Series P1V-A360									
3,600	6000	3000	11,5	17,0	80	G1	22/32	16,0	P1V-A360A0600

* Idling speed

P1V-A160A0900

M, torque [Nm]

P, power [W]

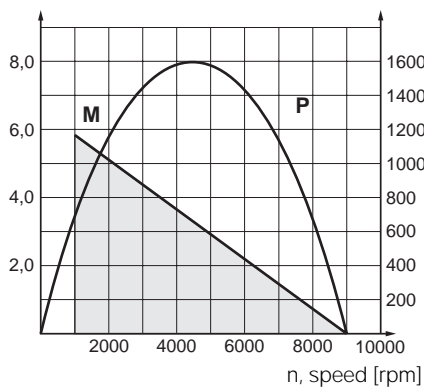

P1V-A260A0700

M, torque [Nm]

P, power [W]

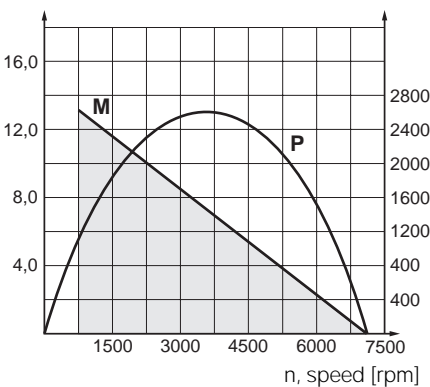

P1V-A360A0600

M, torque [Nm]

P, power [W]

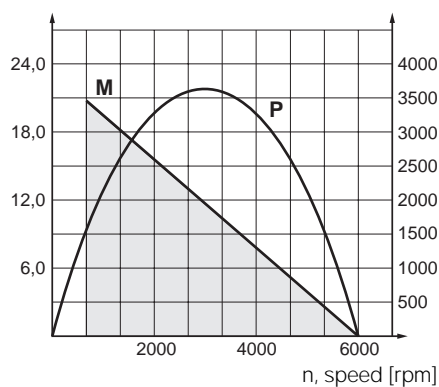

 Working range of motor

Permitted shaft loadings, please refer to page 37

Dimensions, please refer to pages 28-29

NOTE! All technical data are based on a working pressure of 6 bar.

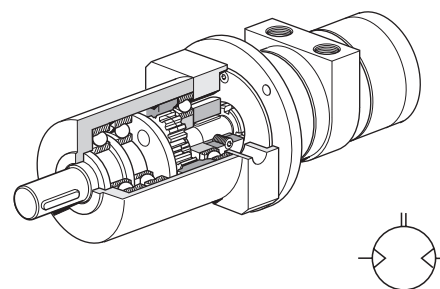

B: Motor with planetary gear, flange mounting. Free installation position

Max power	Max speed	Speed at max power	Torque at max power	Min start torque	Max permitted torque	Air consumption at max power	Con- nec- tion	Min pipe ID inlet/ outlet	Weight	Order code
kW	rpm	rpm	Nm	Nm	Nm	l/s		mm	Kg	
Series P1V-A160										
1,600	1200	900	16	24	190	32	G1/2	19/19	8,3	P1V-A160B0120
1,600	600	450	32	48	190	32	G1/2	19/19	8,3	P1V-A160B0060
1,600	190	180	77	116	480	32	G1/2	19/19	15,4	P1V-A160B0019
1,600	95	90	153	230	480	32	G1/2	19/19	15,4	P1V-A160B0010
Series P1V-A260										
2,600	1200	700	34	51	190	60	G3/4	19/25	12,0	P1V-A260B0120
2,600	600	350	67	101	190	60	G3/4	19/25	12,0	P1V-A260B0060
2,600	190	140	160	240	480	60	G3/4	19/25	13,0	P1V-A260B0019
Series P1V-A360										
3,600	960	600	55	83	480	80	G1	22/32	25,5	P1V-A360B0096
3,600	480	300	110	165	480	80	G1	22/32	25,5	P1V-A360B0048

Permitted shaft loadings, please refer to page 37

Dimensions, please refer to page 30

P1V-A160B0120

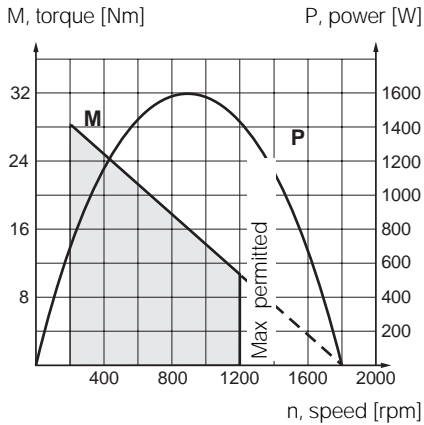

P1V-A160B0060

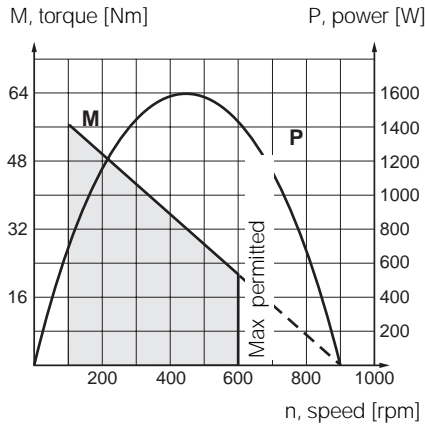

P1V-A160B0019

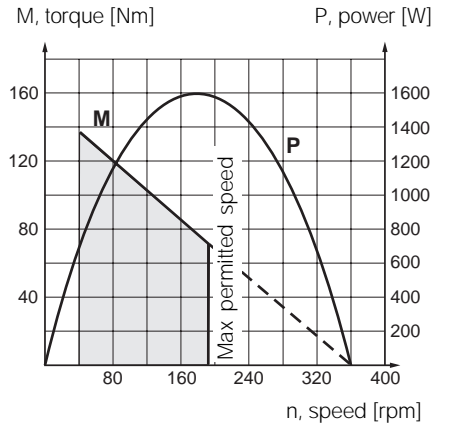

P1V-A160B0010

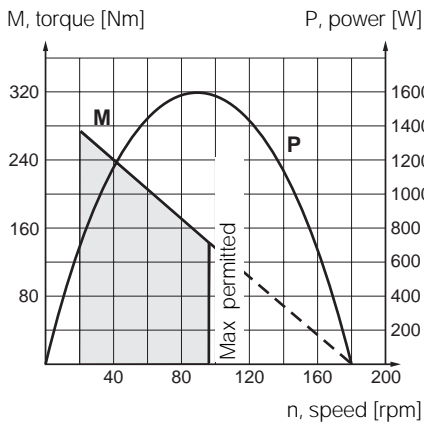

P1V-A260B0120

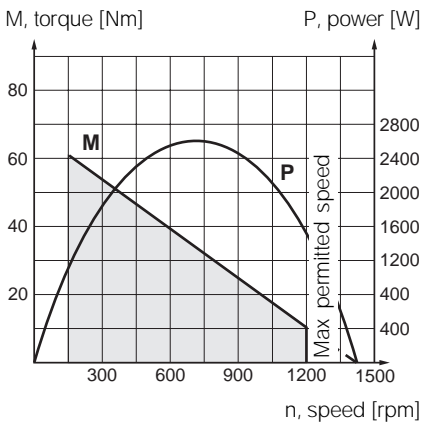

P1V-A260B0060

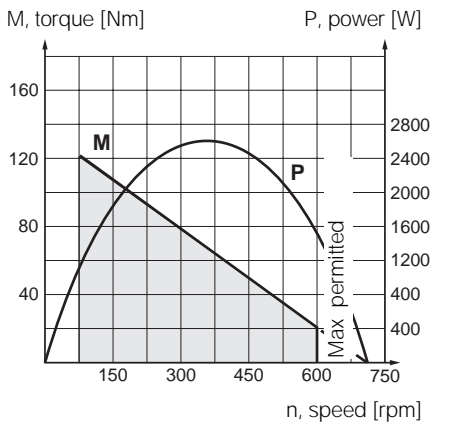

P1V-A260B0019

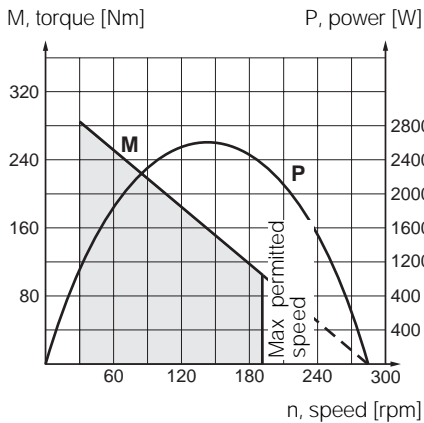

P1V-A360B0096

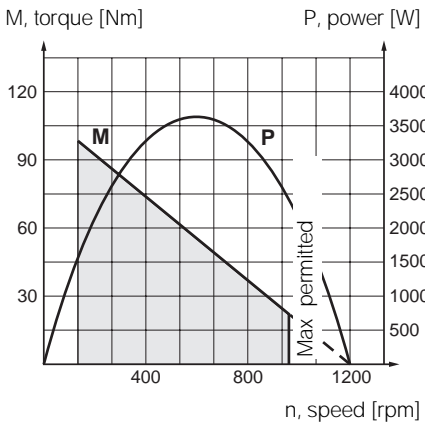

P1V-A360B0048

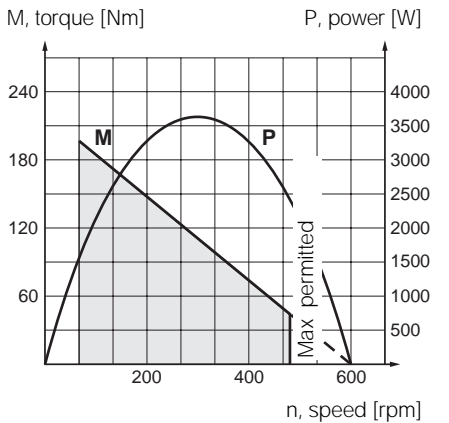

 Working range of motor

NOTE! All technical data are based on a working pressure of 6 bar.

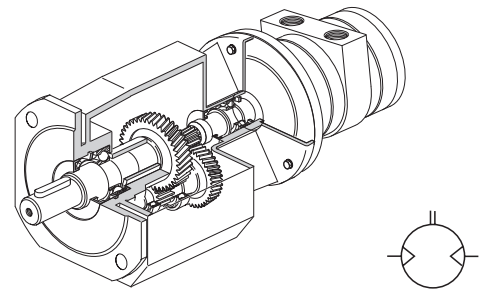

D: Motor with helical gear, flange mounting

Max power kW	Max speed rpm	Speed at max power rpm	Torque at max power Nm	Min start torque Nm	Max permitted torque Nm	Air consumption at max power l/s	Con- nec- tion	Min pipe ID inlet/ outlet mm	Weight Kg	Order code
Series P1V-A160										
1,600	660	590	23	35	70	32	G1/2	19/19	9,5	P1V-A160D0066**
1,600	320	280	49	74	125	32	G1/2	19/19	11,5	P1V-A160D0032**
1,600	140	120	113	170	200	32	G1/2	19/19	14,0	P1V-A160D0014**
1,600	80	70	200	300	430	32	G1/2	19/19	29,0	P1V-A160D0008**
1,600	37	32	415	623	750	32	G1/2	19/19	42,5	P1V-A160D0004**
1,600	25	20	685	1028	1200	32	G1/2	19/19	62,5	P1V-A160D0003**
Series P1V-A260										
2,600	800	565	42	63	70	60	G3/4	19/25	13,8	P1V-A260D0080**
2,600	520	365	65	98	125	60	G3/4	19/25	15,8	P1V-A260D0052**
2,600	250	175	135	203	200	60	G3/4	19/25	18,5	P1V-A260D0025**
2,600	110	80	302	453	430	60	G3/4	19/25	34,0	P1V-A260D0011**
2,600	60	40	565	848	750	60	G3/4	19/25	47,0	P1V-A260D0006**
2,600	30	20	1020	1530	1200	60	G3/4	19/25	67,0	P1V-A260D0003**
Series P1V-A360										
3,600	1050	625	52	78	125	80	G1	22/32	24,5	P1V-A360D0105**
3,600	520	310	105	158	125	80	G1	22/32	24,5	P1V-A360D0052**
3,600	250	150	215	323	430	80	G1	22/32	42,5	P1V-A360D0025**
3,600	125	74	440	660	750	80	G1	22/32	54,5	P1V-A360D0013**
3,600	62	37	850	1275	1200	80	G1	22/32	75,5	P1V-A360D0006**
3,600	30	18	1800	2700	4000	80	G1	22/32	149,5	P1V-A360D0003**

Note!

** specify installation position in the order no. as in the illustrations below.

Example: **P1V-A160D0066B5**

D: Installation positions, helical gears and flange

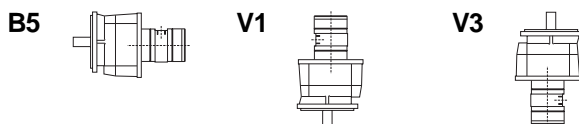

Torque and power graphs, please refer to pages 20-21

Permitted shaft loadings, please refer to page 38

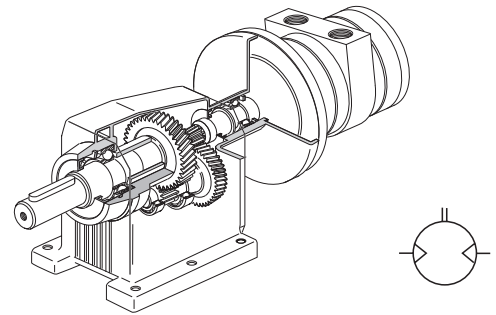

E: Motor with helical gear, foot mounting

Max power kW	Max speed rpm	Speed at max power rpm	Torque at max power Nm	Min start torque Nm	Max permitted torque Nm	Air consumption at max power l/s	Con- nec- tion	Min pipe ID inlet/ outlet mm	Weight Kg	Order code
Series P1V-A160										
1,600	660	590	23	35	70	32	G1/2	19/19	9,8	P1V-A160E0066••
1,600	320	280	49	74	125	32	G1/2	19/19	11,5	P1V-A160E0032••
1,600	140	120	113	170	200	32	G1/2	19/19	14,5	P1V-A160E0014••
1,600	80	70	200	300	430	32	G1/2	19/19	31,2	P1V-A160E0008••
1,600	37	32	415	623	750	32	G1/2	19/19	44,5	P1V-A160E0004••
1,600	25	20	685	1028	1200	32	G1/2	19/19	65,2	P1V-A160E0003••
Series P1V-A260										
2,600	800	565	42	63	70	60	G3/4	19/25	13,8	P1V-A260E0080••
2,600	520	365	65	98	125	60	G3/4	19/25	15,8	P1V-A260E0052••
2,600	250	175	135	203	200	60	G3/4	19/25	18,5	P1V-A260E0025••
2,600	110	80	302	453	430	60	G3/4	19/25	34,0	P1V-A260E0011••
2,600	60	40	565	848	750	60	G3/4	19/25	47,0	P1V-A260E0006••
2,600	30	20	1020	1530	1200	60	G3/4	19/25	67,0	P1V-A260E0003••
Series P1V-A360										
3,600	1050	625	52	78	125	80	G1	22/32	24,5	P1V-A360E0105••
3,600	520	310	105	158	125	80	G1	22/32	24,5	P1V-A360E0052••
3,600	250	150	215	323	430	80	G1	22/32	42,5	P1V-A360E0025••
3,600	125	74	440	660	750	80	G1	22/32	54,5	P1V-A360E0013••
3,600	62	37	850	1275	1200	80	G1	22/32	75,5	P1V-A360E0006••
3,600	30	18	1800	2700	4000	80	G1	22/32	149,5	P1V-A360E0003••

Note!

•• specify installation position in the order no. as in the illustrations below.

Example: **P1V-A160E0066V5**

E: Installation positions, helical gears and flange

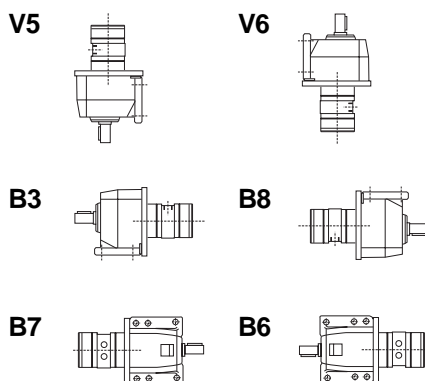

Torque and power graphs, please refer to pages 20-21

Permitted shaft loadings, please refer to page 38

P1V-A160D0066**
P1V-A160E0066**

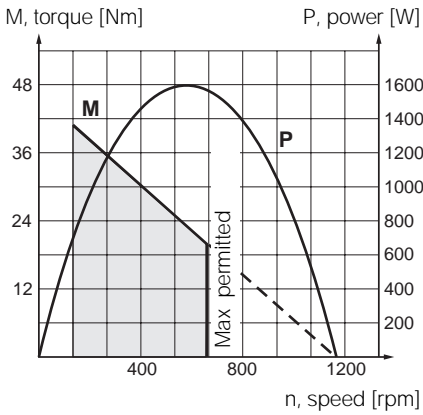

P1V-A160D0032**
P1V-A160E0032**

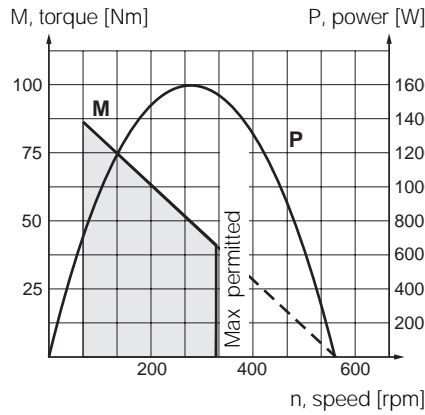

P1V-A160D0014**
P1V-A160E0014**

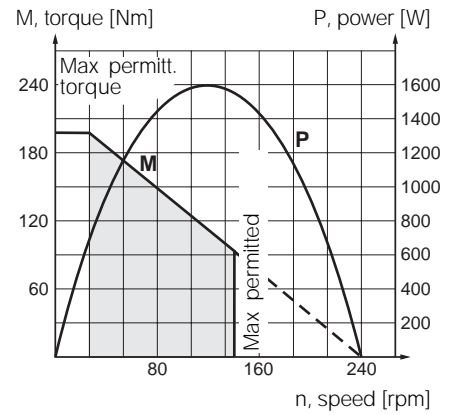

P1V-A160D0008**
P1V-A160E0008**

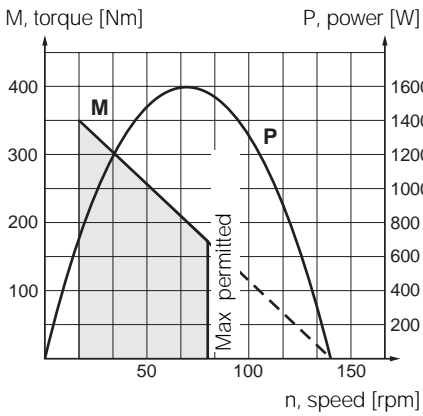

P1V-A160D0004**
P1V-A160E0004**

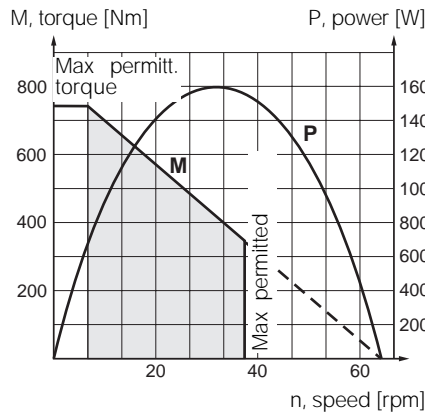

P1V-A160D0003**
P1V-A160E0003**

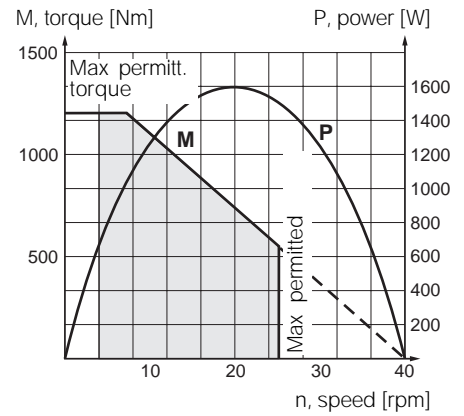

P1V-A260D0060**
P1V-A260E0060**

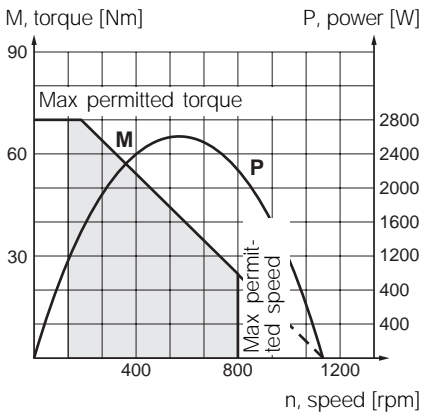

P1V-A260D0052**
P1V-A260E0052**

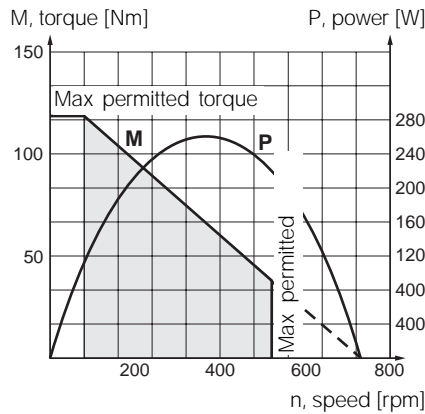

P1V-A260D0025**
P1V-A260E0025**

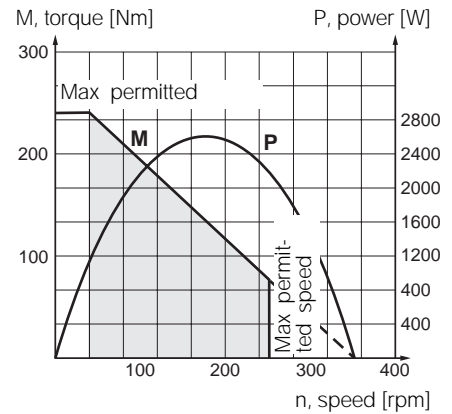

 Working range of motor

P1V-A260D0011••
P1V-A260E0011••

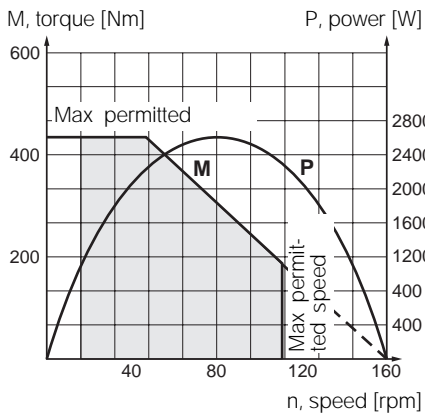

P1V-A260D0006••
P1V-A260E0006••

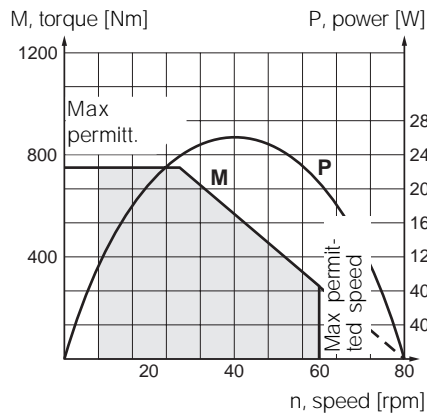

P1V-A260D0003••
P1V-A260E0003••

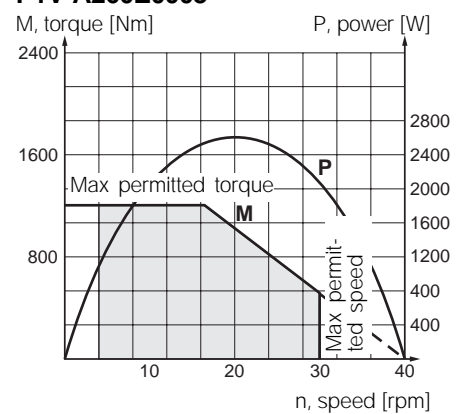

P1V-A360D0105••
P1V-A360E0105••

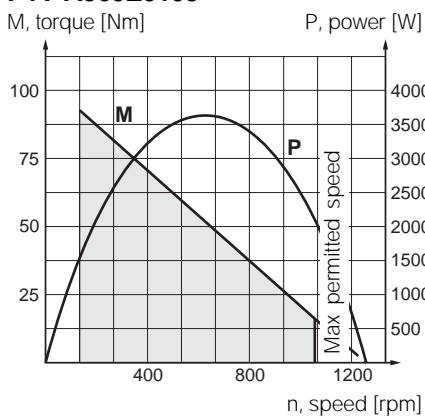

P1V-A360D0052••
P1V-A360E0052••

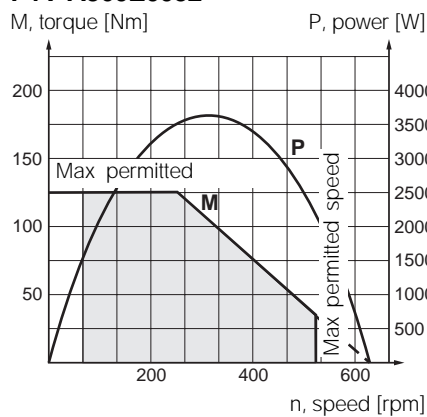

P1V-A360D0025••
P1V-A360E0025••

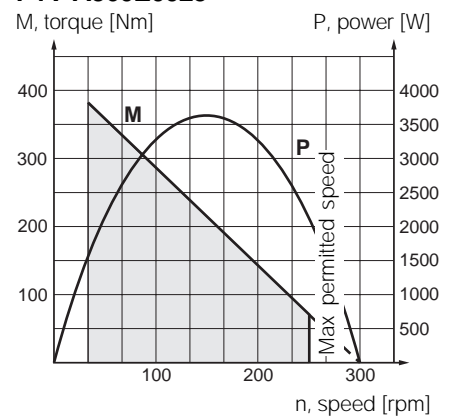

P1V-A360D0013••
P1V-A360E0013••

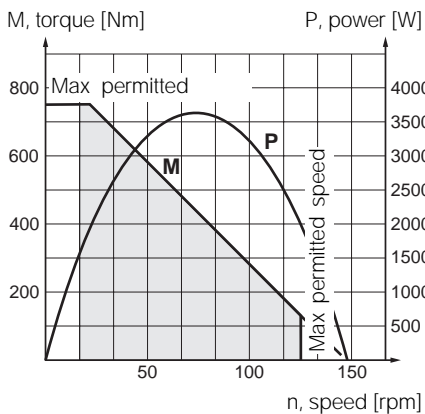

P1V-A360D0006••
P1V-A360E0006••

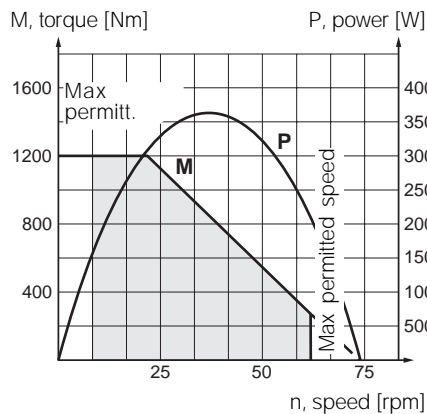

P1V-A360D0003••
P1V-A360E0003••

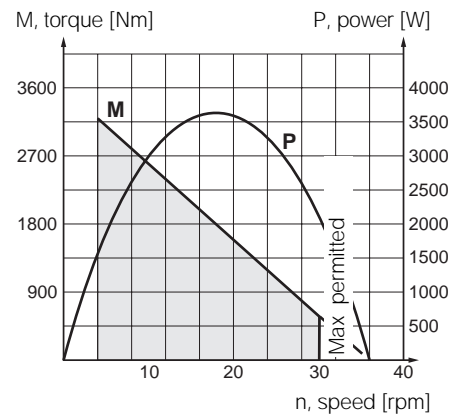

 Working range of motor

NOTE! All technical data are based on a working pressure of 6 bar.

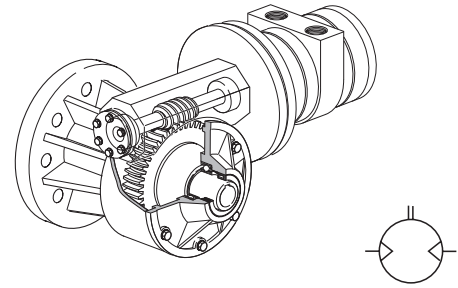

F: Motor with worm gear, flange mounting left-hand

Max power	Max speed	Speed at max power	Torque at max power	Min start torque	Max permitted torque	Types of self-locking	Air consumption at max power	Con-nection	Min pipe ID inlet/ outlet	Weight	Order code
kW	1/min	1/min	Nm	Nm	Nm		l/s		mm	Kg	
Series P1V-A160											
1,600	430	320	38	57	88	1	32	G1/2	19/19	7,2	P1V-A160F0043••
1,600	200	150	76	114	180	2	32	G1/2	19/19	10,2	P1V-A160F0020••
1,600	95	70	150	225	430	3	32	G1/2	19/19	20,5	P1V-A160F0010••
1,600	75	55	178	267	430	3	32	G1/2	19/19	20,5	P1V-A160F0008••
Series P1V-A260											
2,600	500	350	60	90	88	1	60	G3/4	19/25	11,0	P1V-A260F0050••
2,600	220	150	137	206	430	1	60	G3/4	19/25	21,0	P1V-A260F0022••
2,600	125	85	220	330	430	2	60	G3/4	19/25	21,0	P1V-A260F0013••
2,600	62	40	414	621	1500	3	60	G3/4	19/25	57,0	P1V-A260F0008••
Series P1V-A360											
3,600	500	300	100	150	180	1	80	G1	22/32	22,5	P1V-A360F0050••
3,600	220	130	222	333	430	1	80	G1	22/32	33,0	P1V-A360F0022••
3,600	125	75	368	552	800	2	80	G1	22/32	49,0	P1V-A360F0013••
3,600	62	37	670	1005	1500	3	80	G1	22/32	65,5	P1V-A360F0006••

Note!

•• specify installation position in the order no. as in the illustrations below.

Example: **P1V-A160F0066B3**

F: Installation positions, worm gear and flange, left-hand

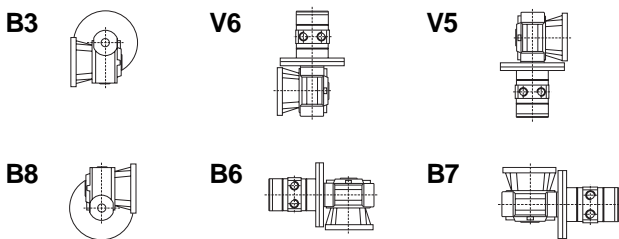

Torque and power graphs, please refer to pages 20-21

Permitted shaft loadings, please refer to page 38

NOTE!

As standard, the motor has a hollow shaft with key slot. Single-ended and double-ended shafts with keys are available as accessories, please refer to page 25.

Self-locking

Dynamic self-locking means that the force acting on the output shaft of the gear can not turn the gear further when the air motor is stopped. Dynamic self-locking is only possible when the gear ratio is high, and at low speeds. None of our worm drive gears are completely self-locking in dynamic conditions.

Static self-locking means that the force acting on the output shaft of the gear can not begin to turn the shaft.

When loads with considerable momentum are driven, it is necessary to have a braking time sufficient to stop the gearbox from being overloaded. It is extremely important that the maximum permitted torque is not exceeded.

Tip: Braking of the air motor can be arranged by either slowly restricting the air supply to the motor until it is completely shut off, or by slowly reducing the supply pressure to zero.

Types of Self-locking

1. Static, not self-locking
2. Static, self-locking - quicker return under vibration - not dynamically self-locking
3. Static, self-locking - return only possible under vibration - good dynamic self-locking



Important!

Since it is practically impossible to guarantee total self-locking, an external brake must be used to guarantee that vibration can not cause an output shaft to move.

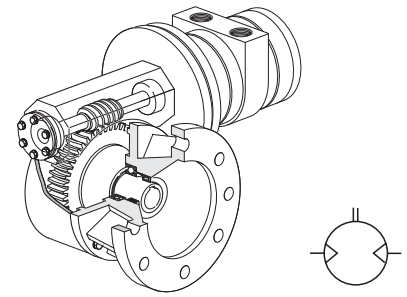

G: Motor with worm gear, flange mounting, right-hand

Max power kW	Max speed 1/min	Speed at max power 1/min	Torque at max power Nm	Min start torque Nm	Max permitted torque Nm	Types of self-locking	Air consumption at max power l/s	Con- nec- tion	Min pipe ID inlet/ outlet mm	Weight Kg	Order code
Series P1V-A160											
1,600	430	320	38	57	88	1	32	G1/2	19/19	7,2	P1V-A160G0043**
1,600	200	150	76	114	180	2	32	G1/2	19/19	10,2	P1V-A160G0020**
1,600	95	70	150	225	430	3	32	G1/2	19/19	20,5	P1V-A160G0010**
1,600	75	55	178	267	430	3	32	G1/2	19/19	20,5	P1V-A160G0008**
Series P1V-A260											
2,600	500	350	60	90	88	1	60	G3/4	19/25	11,0	P1V-A260G0050**
2,600	220	150	137	206	430	1	60	G3/4	19/25	21,0	P1V-A260G0022**
2,600	125	85	220	330	430	2	60	G3/4	19/25	21,0	P1V-A260G0013**
2,600	62	40	414	621	1500	3	60	G3/4	19/25	57,0	P1V-A260G0008**
Series P1V-A360											
3,600	500	300	100	150	180	1	80	G1	22/32	22,5	P1V-A360G0050**
3,600	220	130	222	333	430	1	80	G1	22/32	33,0	P1V-A360G0022**
3,600	125	75	368	552	800	2	80	G1	22/32	49,0	P1V-A360G0013**
3,600	62	37	670	1005	1500	3	80	G1	22/32	65,5	P1V-A360G0006**

Note!

•• specify installation position in the order no. as in the illustrations below.

Example: **P1V-A160G0066B3**

G: Installation positions, worm gear and flange, right-hand

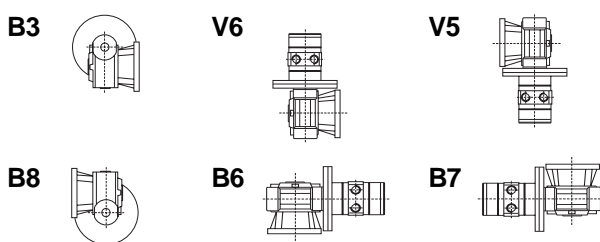

Torque and power graphs, please refer to pages 20-21

Permitted shaft loadings, please refer to page 38

NOTE!

As standard, the motor has a hollow shaft with key slot. Single-ended and double-ended shafts with keys are available as accessories, please refer to page 25.

Self-locking

Dynamic self-locking means that the force acting on the output shaft of the gear can not turn the gear further when the air motor is stopped. Dynamic self-locking is only possible when the gear ratio is high, and at low speeds. None of our worm drive gears are completely self-locking in dynamic conditions.

Static self-locking means that the force acting on the output shaft of the gear can not begin to turn the shaft.

When loads with considerable momentum are driven, it is necessary to have a braking time sufficient to stop the gearbox from being overloaded. It is extremely important that the maximum permitted torque is not exceeded.

Tip: Braking of the air motor can be arranged by either slowly restricting the air supply to the motor until it is completely shut off, or by slowly reducing the supply pressure to zero.

Types of Self-locking

1. Static, not self-locking
2. Static, self-locking - quicker return under vibration - not dynamically self-locking
3. Static, self-locking - return only possible under vibration - good dynamic self-locking



Important!

Since it is practically impossible to guarantee total self-locking, an external brake must be used to guarantee that vibration can not cause an output shaft to move.

NOTE! All technical data are based on a working pressure of 6 bar.

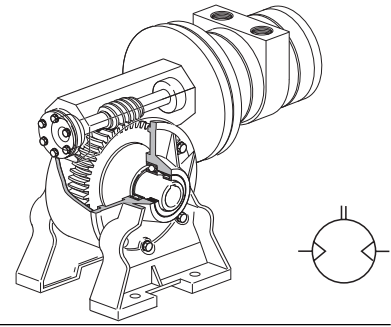

H: Motor with worm gear, foot mounting

Max power	Max speed	Speed at max power	Torque at max power	Min start torque	Max permitted torque	Types of self-locking	Air consumption at max power	Con-nection	Min pipe ID inlet/ outlet	Weight	Order code
kW	1/min	1/min	Nm	Nm	Nm		l/s		mm	Kg	
Series P1V-A160											
1,600	430	320	38	57	88	1	32	G1/2	19/19	7,2	P1V-A160H0043••
1,600	200	150	76	114	180	2	32	G1/2	19/19	10,2	P1V-A160H0020••
1,600	95	70	150	225	430	3	32	G1/2	19/19	20,5	P1V-A160H0010••
1,600	75	55	178	267	430	3	32	G1/2	19/19	20,5	P1V-A160H0008••
Series P1V-A260											
2,600	500	350	60	90	88	1	60	G3/4	19/25	11,0	P1V-A260H0050••
2,600	220	150	137	206	430	1	60	G3/4	19/25	21,0	P1V-A260H0022••
2,600	125	85	220	330	430	2	60	G3/4	19/25	21,0	P1V-A260H0013••
2,600	62	40	414	621	1500	3	60	G3/4	19/25	57,0	P1V-A260H0008••
Series P1V-A360											
3,600	500	300	100	150	180	1	80	G1	22/32	22,5	P1V-A360H0050••
3,600	220	130	222	333	430	1	80	G1	22/32	33,0	P1V-A360H0022••
3,600	125	75	368	552	800	2	80	G1	22/32	49,0	P1V-A360H0013••
3,600	62	37	670	1005	1500	3	80	G1	22/32	65,5	P1V-A360H0006••

Note!

•• specify installation position in the order no. as in the illustrations below.

Example: **P1V-A160H006B3**

H: Installation positions, worm gear and foot

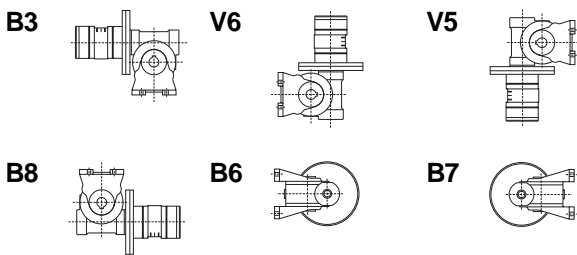

Torque and power graphs, please refer to pages 20-21

Permitted shaft loadings, please refer to page 38

NOTE!

As standard, the motor has a hollow shaft with key slot. Single-ended and double-ended shafts with keys are available as accessories, please refer to page 25.

Self-locking

Dynamic self-locking means that the force acting on the output shaft of the gear can not turn the gear further when the air motor is stopped. Dynamic self-locking is only possible when the gear ratio is high, and at low speeds. None of our worm drive gears are completely self-locking in dynamic conditions.

Static self-locking means that the force acting on the output shaft of the gear can not begin to turn the shaft.

When loads with considerable momentum are driven, it is necessary to have a braking time sufficient to stop the gearbox from being overloaded. It is extremely important that the maximum permitted torque is not exceeded.

Tip: Braking of the air motor can be arranged by either slowly restricting the air supply to the motor until it is completely shut off, or by slowly reducing the supply pressure to zero.

Types of Self-locking

1. Static, not self-locking
2. Static, self-locking - quicker return under vibration - not dynamically self-locking
3. Static, self-locking - return only possible under vibration - good dynamic self-locking



Important!

Since it is practically impossible to guarantee total self-locking, an external brake must be used to guarantee that vibration can not cause an output shaft to move.

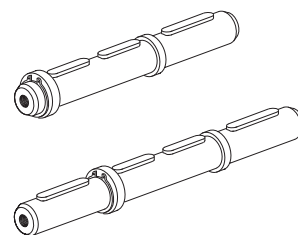

Shaft with keys for P1V-A with worm gear

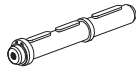
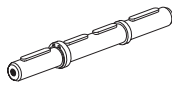
Motor type	Single-ended shaft Order code	Weight kg	Double-ended shaft Order code	Weight kg
				
Serie P1V-A160				
P1V-A160■0043●●	9121 5102-42	0,60	9121 5102-47	0,77
P1V-A160■0020●●	9121 5102-43	0,75	9121 5102-48	0,95
P1V-A160■0010●●	9121 5102-44	1,60	9121 5102-49	2,00
P1V-A160■0008●●	9121 5102-44	1,60	9121 5102-49	2,00
Serie P1V-A260				
P1V-A260■0050●●	9121 5102-42	0,60	9121 5102-47	0,77
P1V-A260■0022●●	9121 5102-44	1,60	9121 5102-49	2,00
P1V-A260■0013●●	9121 5102-44	1,60	9121 5102-49	2,00
P1V-A260■0008●●	9121 5102-46	3,20	9121 5102-51	4,10
Serie P1V-A360				
P1V-A360■0050●●	9121 5102-43	0,75	9121 5102-48	0,95
P1V-A360■0022●●	9121 5102-44	1,60	9121 5102-49	2,00
P1V-A360■0013●●	9121 5102-45	2,80	9121 5102-50	3,60
P1V-A360■0006●●	9121 5102-46	3,20	9121 5102-51	4,10

■ Motor with worm gear (functions F, G and H)

●● Installation position, optional

Dimensions, please refer to page 36

P1V-A160F0043**
P1V-A160G0043**
P1V-A160H0043**

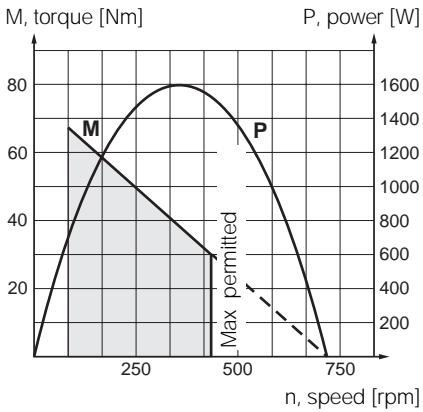

P1V-A160F0020**
P1V-A160G0020**
P1V-A160H0020**

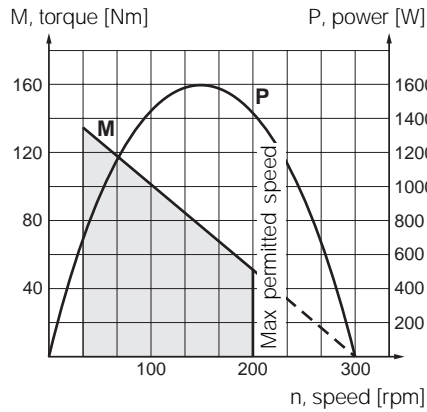

P1V-A160F0010**
P1V-A160G0010**
P1V-A160H0010**

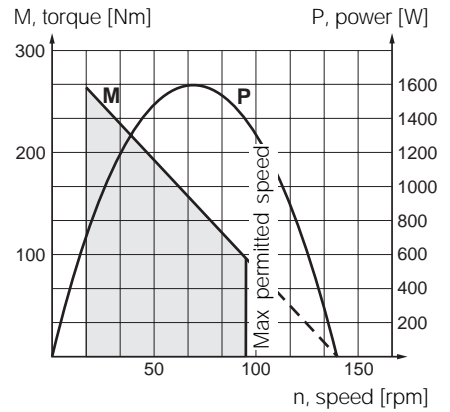

P1V-A160F0008**
P1V-A160G0008**
P1V-A160H0008**

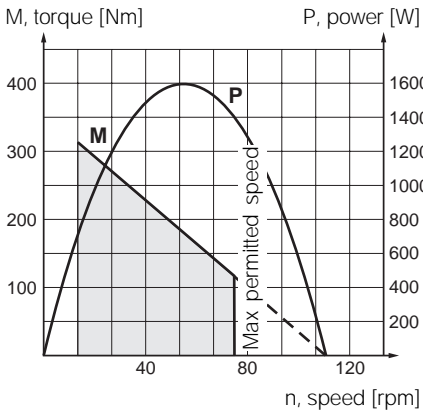

P1V-A260F0050**
P1V-A260G0050**
P1V-A260H0050**

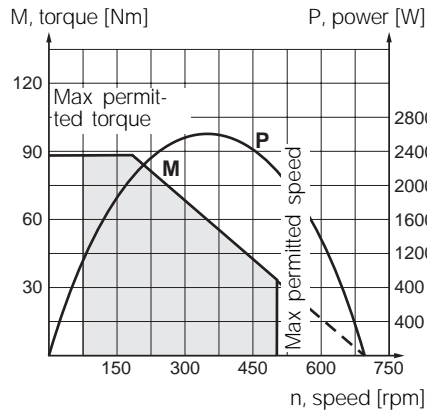

P1V-A260F0022**
P1V-A260G0022**
P1V-A260H0022**

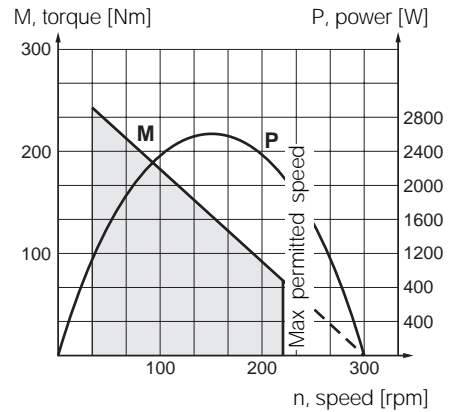

P1V-A260F0013**
P1V-A260G0013**
P1V-A260H0013**

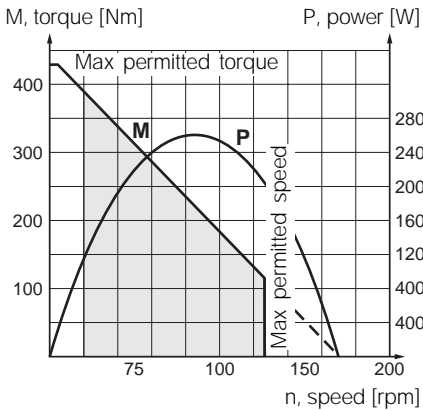

P1V-A260F0008**
P1V-A260G0008**
P1V-A260H0008**

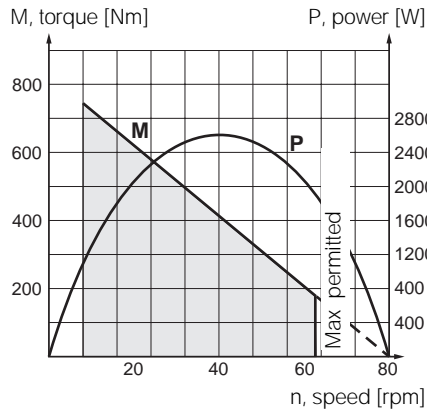

 Working range of motor

P1V-A360F0050
P1V-A360G0050
P1V-A360H0050

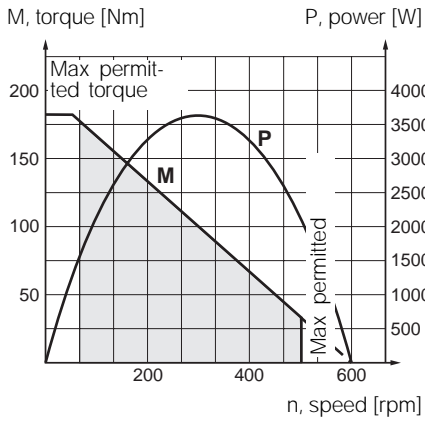

P1V-A360F0022
P1V-A360G0022
P1V-A360H0022

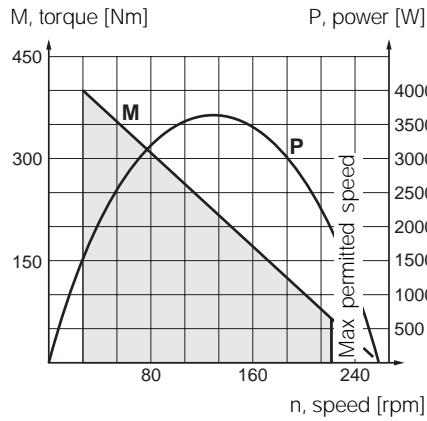

P1V-A360F0013
P1V-A360G0013
P1V-A360H0013

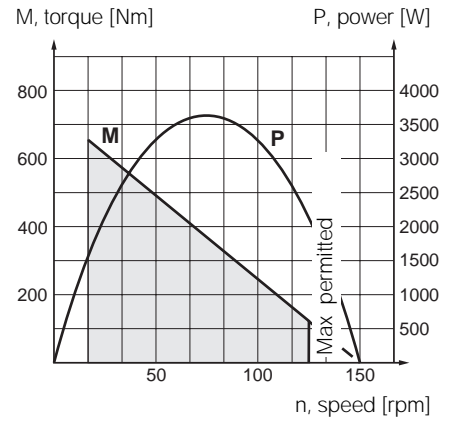

P1V-A360F0006
P1V-A360G0006
P1V-A360H0006

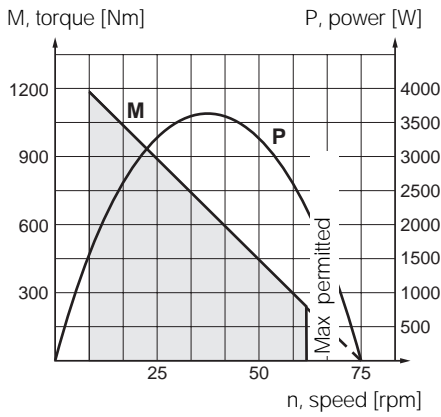

 Working range of motor

Dimensions (mm)

Motor P1V-A160A0900
Flange IEC 71 A B5

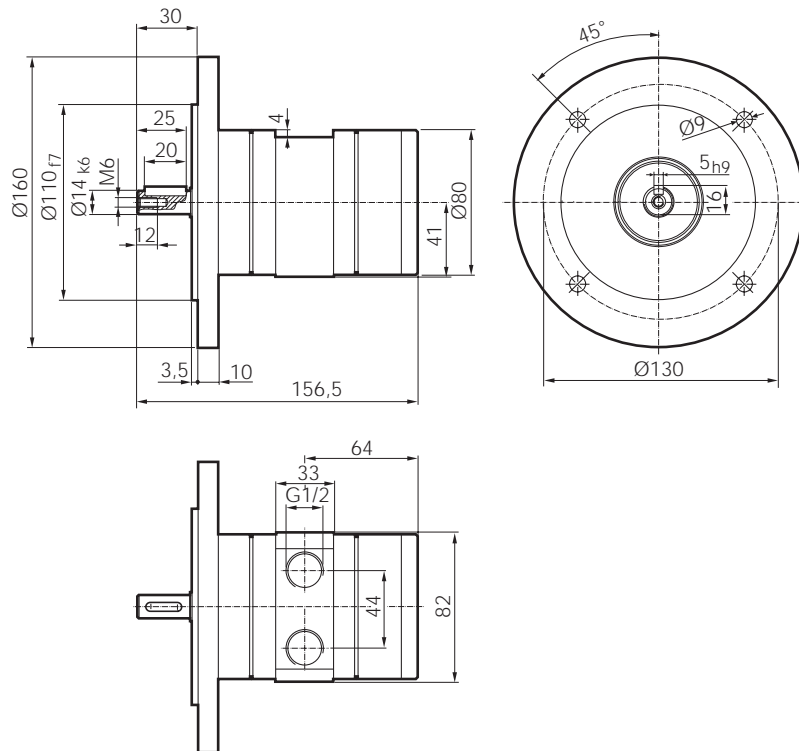

Motor P1V-A260A0700
Flange IEC 80 A B5

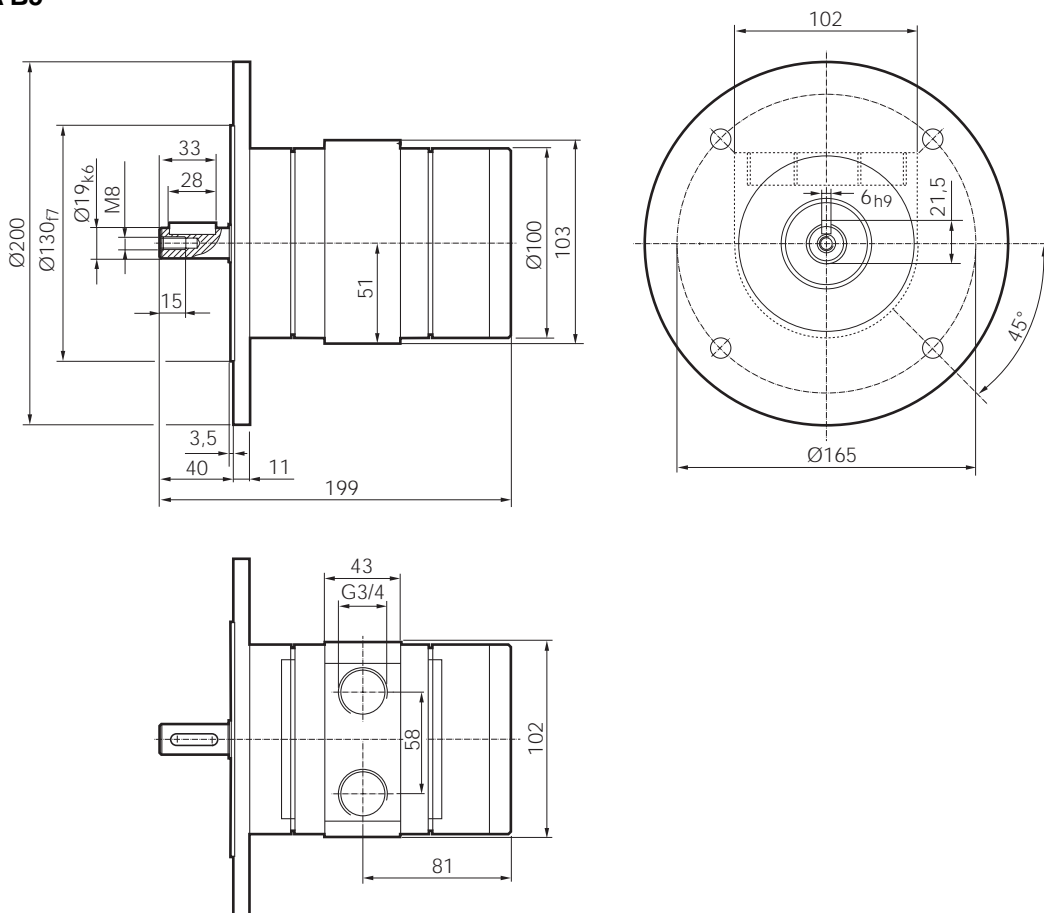

Dimensions (mm)

Motor P1V-A360A0600

Flange IEC 90 A B5

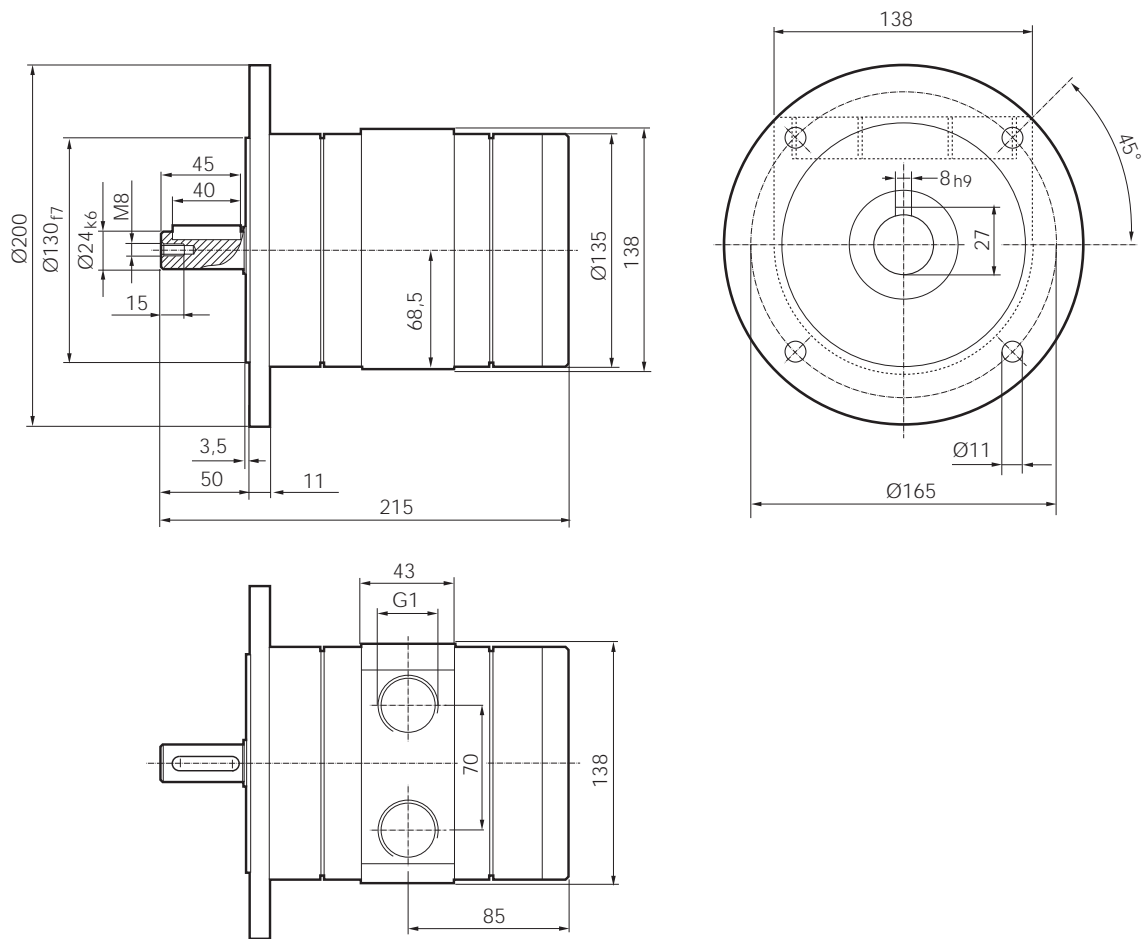

Dimensions (mm)

Motor with planetary gear

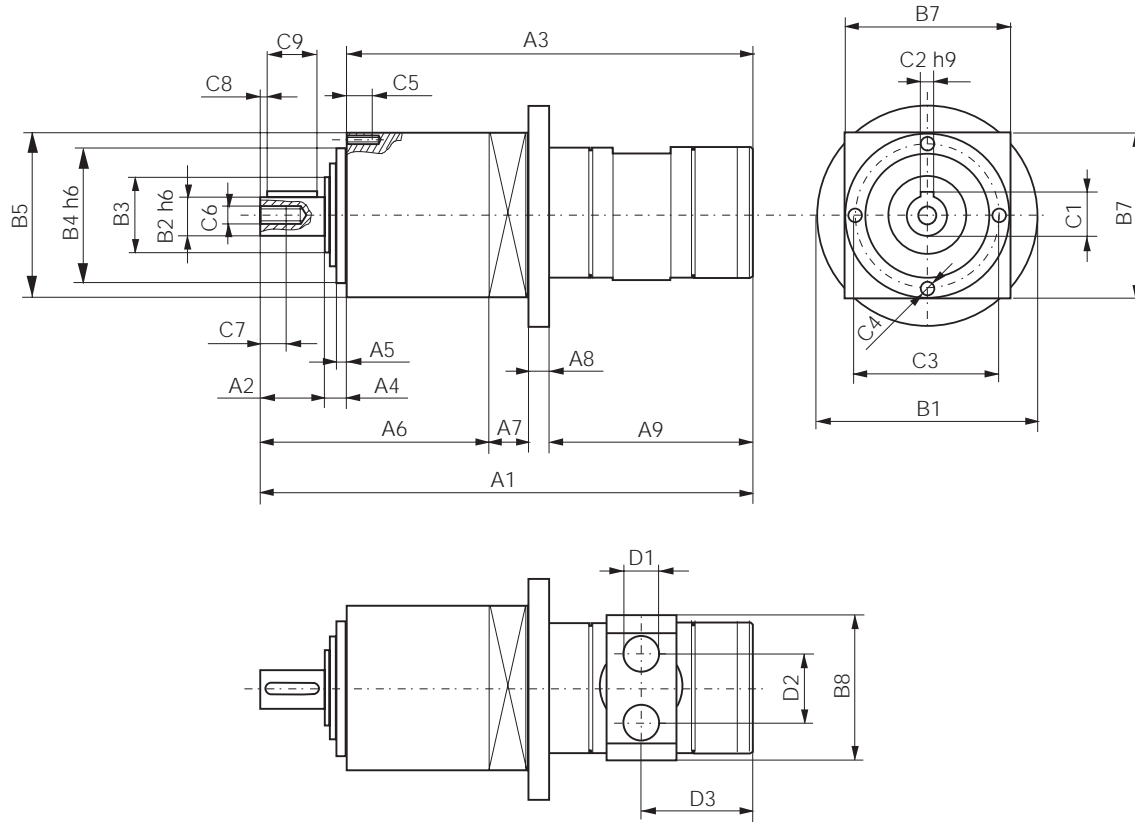

Order code	A1	A2	A3	A4	A5	A6	A7	A8	A9	B1	B2	B3	B4	B5	B6
P1V-A160B0120	274,5	36	228,5	10	5	126,0	22	10	116,5	160	22	40	68	90	80
P1V-A160B0060	274,5	36	228,5	10	5	126,0	22	10	116,5	160	22	40	68	90	80
P1V-A160B0019	359,0	58	289,0	12	5	204,5	28	10	116,5	160	32	50	90	120	80
P1V-A160B0010	359,0	58	289,0	12	5	204,5	28	10	116,5	160	32	50	90	120	80
P1V-A260B0120	317,0	36	271,0	10	6	126,0	32	11	148,0	200	22	40	68	90	100
P1V-A260B0060	317,0	36	271,0	10	6	126,0	32	11	148,0	200	22	40	68	90	100
P1V-A260B0019	391,5	58	321,5	12	6	204,5	28	11	148,0	200	32	50	90	120	100
P1V-A360B0096	375,0	58	305,0	12	6	172,0	38	11	154,0	200	32	50	90	120	135
P1V-A360B0048	375,0	58	305,0	12	6	172,0	38	11	154,0	200	32	50	90	120	135

Order code	B7	B8	C1	C2	C3	C4	C5	C6	C7	C8	C9	D1	D2	D3
P1V-A160B0120	120	85	24,5	6	80	M6	12	M8	13	2	32	G1/2	44	64
P1V-A160B0060	120	85	24,5	6	80	M6	12	M8	13	2	32	G1/2	44	64
P1V-A160B0019	120	85	35,0	10	108	M8	16	M12	22	4	50	G1/2	44	64
P1V-A160B0010	120	85	35,0	10	108	M8	16	M12	22	4	50	G1/2	44	64
P1V-A260B0120	140	102	24,5	6	80	M6	12	M8	13	2	32	G3/4	58	81
P1V-A260B0060	140	102	24,5	6	80	M6	12	M8	13	2	32	G3/4	58	81
P1V-A260B0019	140	102	35,0	10	108	M8	16	M12	22	4	50	G3/4	58	81
P1V-A360B0096	140	138	35,0	10	108	M8	16	M12	22	4	50	G1	70	85
P1V-A360B0048	140	138	35,0	10	108	M8	16	M12	22	4	50	G1	70	85

Dimensions (mm)

Motor with helical gear, flange mounting

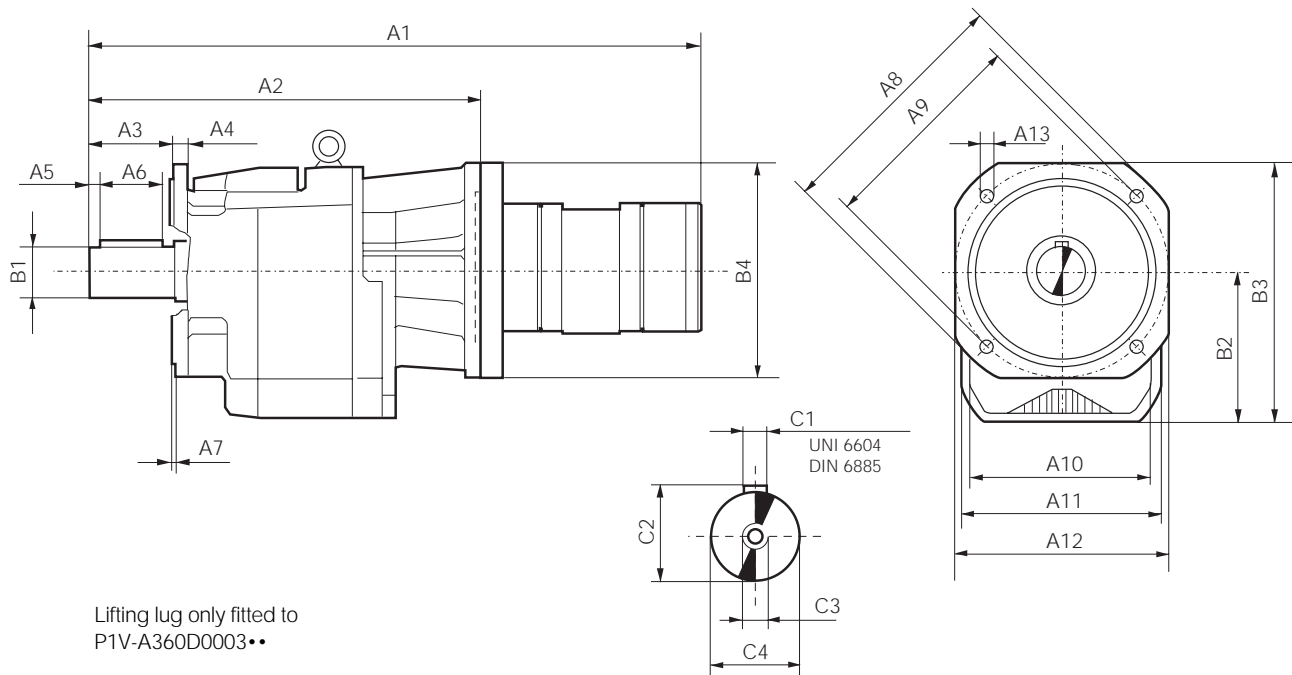

Order code	A1	A2	A3	A4	A5	A6	A7	A8	A9	A10	A11	A12	A13	B1	B2	B3
P1V-A160D0066••	370,5	244	40	8	5	30	3,0	140	115	95f7	95	105	9,5	20	82	138,0
P1V-A160D0032••	399,5	273	50	10	5	40	3,5	160	130	110f7	110	135	9,5	25	92	159,5
P1V-A160D0014••	433,5	307	60	12	5	50	3,5	200	165	130f7	130	150	11,5	30	108	183,0
P1V-A160D0008••	463,5	337	70	13	5	60	4,0	250	215	180 f7	155	210	14,0	35	128	233,0
P1V-A160D0004••	559,5	433	80	16	5	70	5,0	300	265	230 f7	185	260	14,0	40	152	282,0
P1V-A160D0003••	601,5	475	100	16	5	90	5,0	300	265	230 f7	210	260	14,0	50	190	320,0
P1V-A260D0080••	423,0	264	40	8	5	30	3,0	140	115	95f7	95	105	9,5	20	82	138,0
P1V-A260D0052••	451,0	292	50	10	5	40	3,5	160	130	110f7	110	135	9,5	25	92	159,5
P1V-A260D0025••	486,0	327	60	12	5	50	3,5	200	165	130f7	130	150	11,5	30	108	183,0
P1V-A260D0011••	515,0	356	70	13	5	60	4,0	250	215	180 f7	155	210	14,0	35	128	233,0
P1V-A260D0006••	612,0	453	80	16	5	70	5,0	300	265	230 f7	185	260	14,0	40	152	282,0
P1V-A260D0003••	634,0	475	100	16	5	90	5,0	300	265	230 f7	210	260	14,0	50	190	320,0
P1V-A360D0105••	458,0	292	50	10	5	40	3,5	160	130	110f7	110	135	9,5	25	92	159,5
P1V-A360D0052••	458,0	292	50	10	5	40	3,5	160	130	110f7	110	135	9,5	25	92	159,5
P1V-A360D0025••	521,0	356	70	13	5	60	4,0	250	215	180 f7	155	210	14,0	35	128	233,0
P1V-A360D0013••	547,0	382	80	16	5	70	5,0	300	265	230 f7	185	260	14,0	40	152	282,0
P1V-A360D0006••	640,0	475	100	16	5	90	5,0	300	265	230 f7	210	260	14,0	50	190	320,0
P1V-A360D0003••	699,0	534	140	20	15	110	5,0	400	350	300 f7	320	350	18,0	80	247	424,0

Order code	B4	C1	C2	C3	C4
P1V-A160D0066••	160	6x6x30	22,5	M8x19	20 h6
P1V-A160D0032••	160	8x7x40	28,0	M8x19	25 h6
P1V-A160D0014••	160	8x7x50	33,0	M10x22	30 h6
P1V-A160D0008••	160	10x8x60	38,0	M10x22	35 h6
P1V-A160D0004••	160	12x8x70	43,0	M12x28	40 h6
P1V-A160D0003••	160	14x9x90	53,5	M16x36	50 h6
P1V-A260D0080••	200	6x6x30	22,5	M8x19	20 h6
P1V-A260D0052••	200	8x7x40	28,0	M8x19	25 h6
P1V-A260D0025••	200	8x7x50	33,0	M10x22	30 h6
P1V-A260D0011••	200	10x8x60	38,0	M10x22	35 h6
P1V-A260D0006••	200	12x8x70	43,0	M12x28	40 h6
P1V-A260D0003••	200	14x9x90	53,5	M16x36	50 h6
P1V-A360D0105••	200	8x7x40	28,0	M8x19	25 h6
P1V-A360D0052••	200	8x7x40	28,0	M8x19	25 h6
P1V-A360D0025••	200	10x8x60	38,0	M10x22	35 h6
P1V-A360D0013••	200	12x8x70	43,0	M12x28	40 h6
P1V-A360D0006••	200	14x9x90	53,5	M16x36	50 h6
P1V-A360D0003••	200	22x14x110	85,0	M20x42	80 h6

Dimensions (mm)

Motor with helical gear, foot mounting

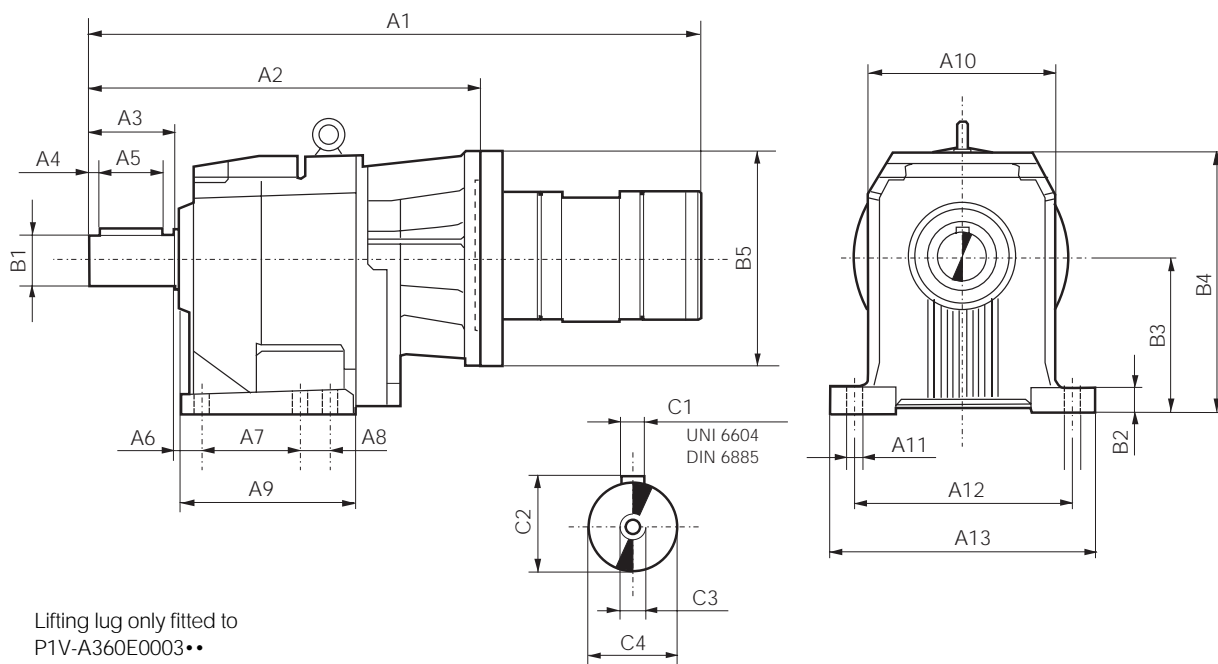

Order code	A1	A2	A3	A4	A5	A6	A7	A8	A9	A10	A11	A12	A13	B1	B2	B3
P1V-A160E0066••	370,5	244	40	5	30	18	50	37,0	107,0	95	9	110	130	20	15	85
P1V-A160E0032••	399,5	273	50	5	40	18	60	47,5	137,0	110	11	130	155	25	17	100
P1V-A160E0014••	433,5	307	60	5	50	18	70	60,0	156,0	130	11	160	190	30	20	110
P1V-A160E0008••	463,5	337	70	5	60	20	105	44,5	185,5	155	14	180	216	35	18	130
P1V-A160E0004••	559,5	433	80	5	70	25	110	46,0	200,0	185	18	225	270	40	22	155
P1V-A160E0003••	601,5	475	100	5	90	25	145	35,0	222,0	210	18	250	300	50	25	195
P1V-A260E0080••	413,0	244	40	5	30	18	50	37,0	107,0	95	9	110	130	20	15	85
P1V-A260E0052••	451,0	292	50	5	40	18	60	47,5	137,0	110	11	130	155	25	17	100
P1V-A260E0025••	486,0	327	60	5	50	18	70	60,0	156,0	130	11	160	190	30	20	110
P1V-A260E0011••	515,0	356	70	5	60	20	105	44,5	185,5	155	14	180	216	35	18	130
P1V-A260E0006••	612,0	453	80	5	70	25	110	46,0	200,0	185	18	225	270	40	22	155
P1V-A260E0003••	654,0	495	100	5	90	25	145	35,0	222,0	210	18	250	300	50	25	195
P1V-A360E0105••	457,0	292	50	5	40	18	60	47,5	137,0	110	11	130	155	25	17	100
P1V-A360E0052••	457,0	292	50	5	40	18	60	47,5	137,0	110	11	130	155	25	17	100
P1V-A360E0025••	521,0	356	70	5	60	20	105	44,5	185,5	155	14	180	216	35	18	130
P1V-A360E0013••	547,0	382	80	5	70	25	110	46,0	200,0	185	18	225	270	40	22	155
P1V-A360E0006••	660,0	495	100	5	90	25	145	35,0	222,0	210	18	250	300	50	25	195
P1V-A360E0003••	699,0	534	140	15	110	33	210	—	277,0	320	26	370	440	80	35	250

Order code	B4	B5	C1	C2	C3	C4
P1V-A160E0066••	141	160	6x6x30	22,5	M8x19	20 h6
P1V-A160E0032••	166	160	8x7x40	28,0	M8x19	25 h6
P1V-A160E0014••	181	160	8x7x50	33,0	M10x22	30 h6
P1V-A160E0008••	223	160	10x8x60	38,0	M10x22	35 h6
P1V-A160E0004••	278	160	12x8x70	43,0	M12x28	40 h6
P1V-A160E0003••	316	160	14x9x90	53,5	M16x36	50 h6
P1V-A260E0080••	141	200	6x6x30	22,5	M8x19	20 h6
P1V-A260E0052••	166	200	8x7x40	28,0	M8x19	25 h6
P1V-A260E0025••	181	200	8x7x50	33,0	M10x22	30 h6
P1V-A260E0011••	223	200	10x8x60	38,0	M10x22	35 h6
P1V-A260E0006••	278	200	12x8x70	43,0	M12x28	40 h6
P1V-A260E0003••	316	200	14x9x90	53,5	M16x36	50 h6
P1V-A360E0105••	166	200	8x7x40	28,0	M8x19	25 h6
P1V-A360E0052••	166	200	8x7x40	28,0	M8x19	25 h6
P1V-A360E0025••	223	200	10x8x60	38,0	M10x22	35 h6
P1V-A360E0013••	278	200	12x8x70	43,0	M12x28	40 h6
P1V-A360E0006••	316	200	14x9x90	53,5	M16x36	50 h6
P1V-A360E0003••	420	200	22x14x110	85,0	M20x42	80 h6

Dimensions (mm)

Motor with worm gear, flange mounting, left-hand

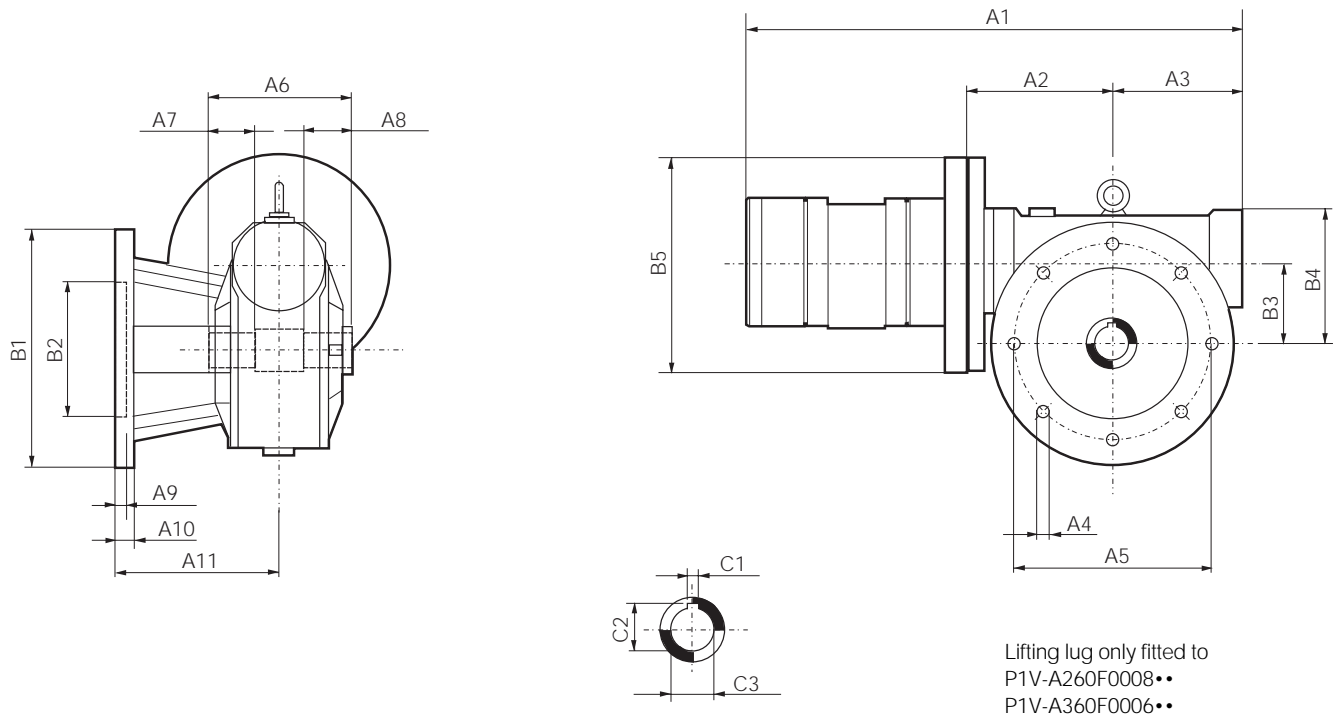

Lifting lug only fitted to
P1V-A260F0008••
P1V-A360F0006••

As standard, the motor has a hollow shaft with key slot. Please refer to page 36 for a dimension sketch of the single ended and double ended shafts.

Order code	A1	A2	A3	A4	A5	A6	A7	A8	A9	A10	A11	B1	B2	B3
P1V-A160F0043••	259,5	70	63	10,5	90	82	22,5	22,5	10	12	85,0	125	70 H8	49,50
P1V-A160F0020••	301,5	95	80	10,5	130	120	40,0	40,0	8	11	116,0	180	115 H8	62,17
P1V-A160F0010••	362,5	126	110	12,5	176	140	45,0	45,0	15	15	151,0	210	152 H8	86,90
P1V-A160F0008••	362,5	126	110	12,5	176	140	45,0	45,0	15	15	151,0	210	152 H8	86,90
P1V-A260F0050••	292,0	70	63	10,5	90	82	22,5	22,5	10	12	85,0	125	70 H8	49,50
P1V-A260F0022••	395,0	126	110	12,5	176	140	45,0	45,0	15	15	151,0	210	152 H8	86,90
P1V-A260F0013••	395,0	126	110	12,5	176	140	45,0	45,0	15	15	151,0	210	152 H8	86,90
P1V-A260F0008••	498,0	185	154	16,0	255	165	52,5	52,5	18	20	197,5	320	180 H8	130,00
P1V-A360F0050••	340,0	95	80	10,5	130	120	40,0	40,0	8	11	116,0	180	115 H8	62,17
P1V-A360F0022••	401,0	126	110	12,5	176	140	45,0	45,0	15	15	151,0	210	152 H8	86,90
P1V-A360F0013••	456,0	153	138	13,5	230	155	45,0	45,0	18	20	179,5	280	170 H8	110,10
P1V-A360F0006••	504,0	185	154	16,0	255	165	52,5	52,5	18	20	197,5	320	180 H8	130,00

Order code	B4	B5	C1	C2	C3
P1V-A160F0043••	80,0	160	8 H8	28,3	25 H7
P1V-A160F0020••	98,5	160	8 H8	28,3	25 H7
P1V-A160F0010••	138,0	160	10 H8	38,3	35 H7
P1V-A160F0008••	138,0	160	10 H8	38,3	35 H7
P1V-A260F0050••	80,0	200	8 H8	28,3	25 H7
P1V-A260F0022••	138,0	200	10 H8	38,3	35 H7
P1V-A260F0013••	138,0	200	10 H8	38,3	35 H7
P1V-A260F0008••	195,0	200	14 H8	48,8	45 H7
P1V-A360F0050••	98,5	200	8 H8	28,3	25 H7
P1V-A360F0022••	138,0	200	10 H8	38,3	35 H7
P1V-A360F0013••	169,0	200	12 H8	45,3	42 H7
P1V-A360F0006••	195,0	200	14 H8	48,8	45 H7

Dimensions (mm)

Motor with worm gear, flange mounting, right-hand

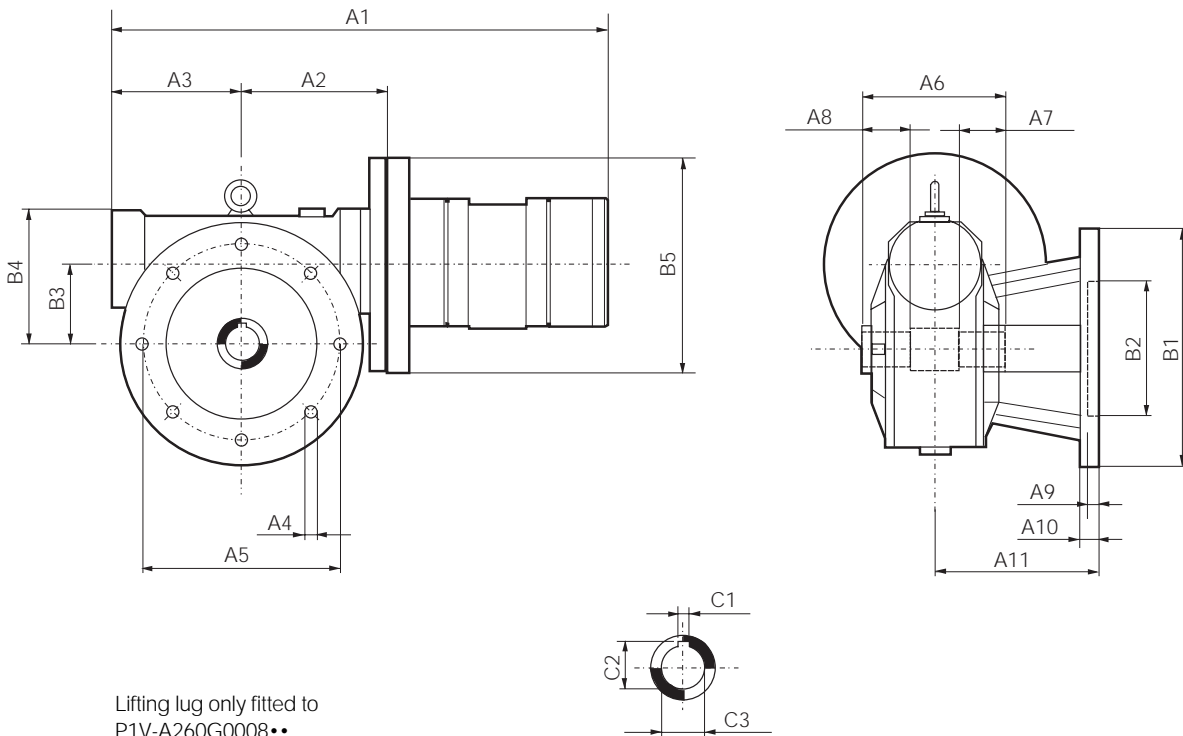

Lifting lug only fitted to
P1V-A260G0008••
P1V-A360G0006••

As standard, the motor has a hollow shaft with key slot. Please refer to page 36 for a dimension sketch of the single ended and double ended shafts.

Order code	A1	A2	A3	A4	A5	A6	A7	A8	A9	A10	A11	B1	B2	B3
P1V-A160G0043••	259,5	70	63	10,5	90	82	22,5	22,5	10	12	85,0	125	70 H8	49,50
P1V-A160G0020••	301,5	95	80	10,5	130	120	40,0	40,0	8	11	116,0	180	115 H8	62,17
P1V-A160G0010••	362,5	126	110	12,5	176	140	45,0	45,0	15	15	151,0	210	152 H8	86,90
P1V-A160G0008••	362,5	126	110	12,5	176	140	45,0	45,0	15	15	151,0	210	152 H8	86,90
P1V-A260G0050••	292,0	70	63	10,5	90	82	22,5	22,5	10	12	85,0	125	70 H8	49,50
P1V-A260G0022••	395,0	126	110	12,5	176	140	45,0	45,0	15	15	151,0	210	152 H8	86,90
P1V-A260G0013••	395,0	126	110	12,5	176	140	45,0	45,0	15	15	151,0	210	152 H8	86,90
P1V-A260G0008••	498,0	185	154	16,0	255	165	52,5	52,5	18	20	197,5	320	180 H8	130,00
P1V-A360G0050••	340,0	95	80	10,5	130	120	40,0	40,0	8	11	116,0	180	115 H8	62,17
P1V-A360G0022••	401,0	126	110	12,5	176	140	45,0	45,0	15	15	151,0	210	152 H8	86,90
P1V-A360G0013••	456,0	153	138	13,5	230	155	45,0	45,0	18	20	179,5	280	170 H8	110,10
P1V-A360G0006••	504,0	185	154	16,0	255	165	52,5	52,5	18	20	197,5	320	180 H8	130,00

Order code	B4	B5	C1	C2	C3
P1V-A160G0043••	80,0	160	8 H8	28,3	25 H7
P1V-A160G0020••	98,5	160	8 H8	28,3	25 H7
P1V-A160G0010••	138,0	160	10 H8	38,3	35 H7
P1V-A160G0008••	138,0	160	10 H8	38,3	35 H7
P1V-A260G0050••	80,0	200	8 H8	28,3	25 H7
P1V-A260G0022••	138,0	200	10 H8	38,3	35 H7
P1V-A260G0013••	138,0	200	10 H8	38,3	35 H7
P1V-A260G0008••	195,0	200	14 H8	48,8	45 H7
P1V-A360G0050••	98,5	200	8 H8	28,3	25 H7
P1V-A360G0022••	138,0	200	10 H8	38,3	35 H7
P1V-A360G0013••	169,0	200	12 H8	45,3	42 H7
P1V-A360G0006••	195,0	200	14 H8	48,8	45 H7

Dimensions (mm)

Motor with worm gear, foot mounting

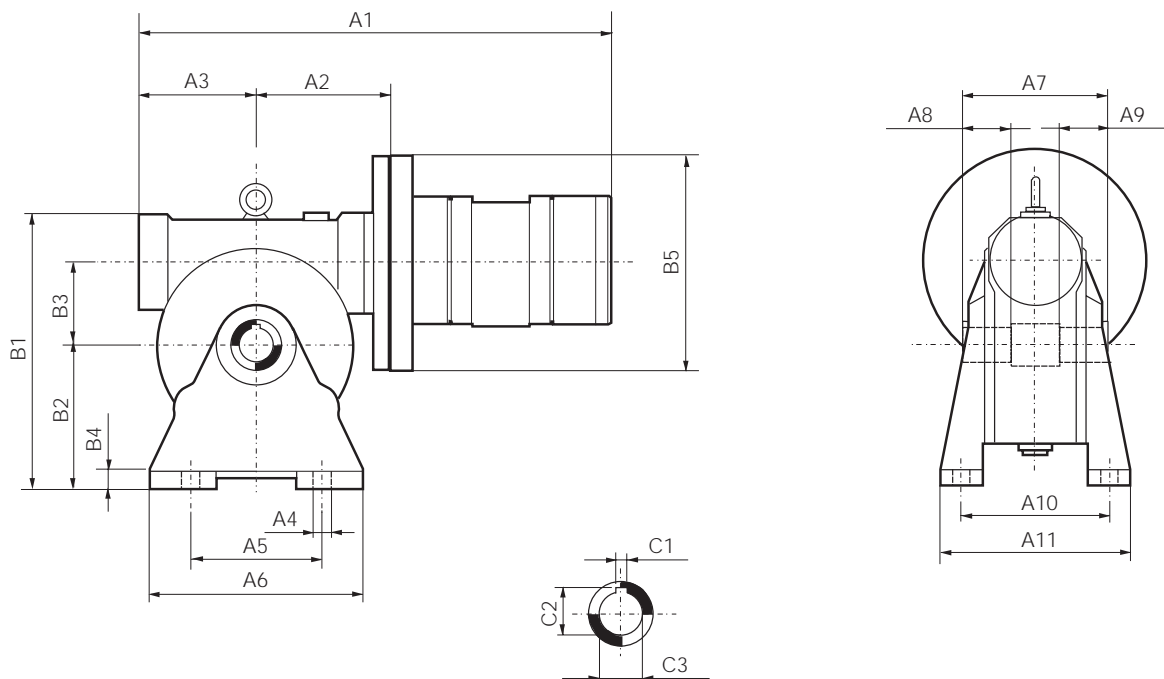

Lifting lug only fitted to
P1V-A260H0008••
P1V-A360H0006••

As standard, the motor has a hollow shaft with key slot. Please refer to page 36 for a dimension sketch of the single ended and double ended shafts.

Order code	A1	A2	A3	A4	A5	A6	A7	A8	A9	A10	A11	B1	B2	B3
P1V-A160H0043••	259,5	70	63	8,5	63	110	82	22,5	22,5	98,5	124	162	82	49,50
P1V-A160H0020••	301,5	95	80	10,5	95	140	120	40,0	40,0	111,0	143	199	100	62,17
P1V-A160H0010••	362,5	126	110	11,0	140	220	140	45,0	45,0	146,0	186	280	142	86,90
P1V-A160H0008••	362,5	126	110	11,0	140	220	140	45,0	45,0	146,0	186	280	142	86,90
P1V-A260H0050••	292,0	70	63	8,5	63	110	82	22,5	22,5	98,5	124	162	82	49,50
P1V-A260H0022••	395,0	126	110	11,0	140	220	140	45,0	45,0	146,0	186	280	142	86,90
P1V-A260H0013••	395,0	126	110	11,0	140	220	140	45,0	45,0	146,0	186	280	142	86,90
P1V-A260H0008••	498,0	185	154	16,0	220	310	165	52,5	52,5	191,0	245	398	195	130,00
P1V-A360H0050••	340,0	95	80	10,5	95	140	120	40,0	40,0	111,0	143	199	100	62,17
P1V-A360H0022••	401,0	126	110	11,0	140	220	140	45,0	45,0	146,0	186	280	142	86,90
P1V-A360H0013••	456,0	138	153	12,5	200	270	155	45,0	45,0	181,0	220	339	170	110,10
P1V-A360H0006••	504,0	185	154	16,0	220	310	165	52,5	52,5	191,0	245	398	195	130,00

Order code	B4	B5	C1	C2	C3
P1V-A160H0043••	12	160	8 H8	28,3	25 H7
P1V-A160H0020••	12	160	8 H8	28,3	25 H7
P1V-A160H0010••	14	160	10 H8	38,3	35 H7
P1V-A160H0008••	14	160	10 H8	38,3	35 H7
P1V-A260H0050••	12	200	8 H8	28,3	25 H7
P1V-A260H0022••	14	200	10 H8	38,3	35 H7
P1V-A260H0013••	14	200	10 H8	38,3	35 H7
P1V-A260H0008••	18	200	14 H8	48,8	45 H7
P1V-A360H0050••	12	200	8 H8	28,3	25 H7
P1V-A360H0022••	14	200	10 H8	38,3	35 H7
P1V-A360H0013••	15	200	12 H8	45,3	42 H7
P1V-A360H0006••	18	200	14 H8	48,8	45 H7

Dimensions (mm)

Shaft with keys for P1V-A motor with worm gear

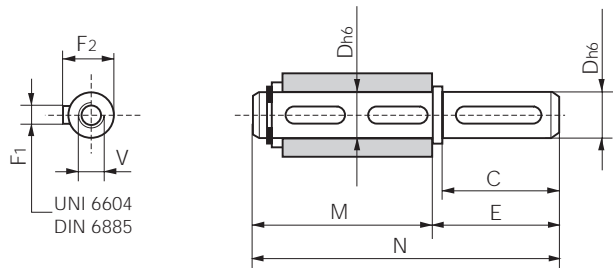

Single-ended shaft

Order code	C	D	E	F1	F2	M	N	V
9121 5102-42	60	25	65	8	28,0	89	154	M8x20
9121 5102-43	60	25	65	8	28,0	127	192	M8x20
9121 5102-44	60	35	65	10	38,0	149	214	M10x25
9121 5102-45	75	42	80	12	45,0	164	244	M12x32
9121 5102-46	80	45	85	14	48,5	176	261	M12x32

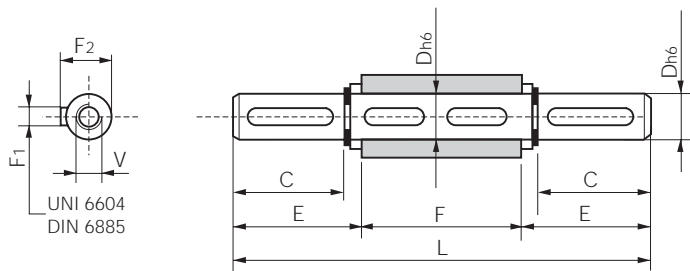

Double-ended shaft

Order code	C	D	E	F	F1	F2	L	V
9121 5102-47	60	25	63,20	82	8	28,0	208,4	M8x20
9121 5102-48	60	25	63,20	120	8	28,0	246,4	M8x20
9121 5102-49	60	35	64,00	140	10	38,0	268,0	M10x25
9121 5102-50	75	42	79,25	155	12	45,0	313,5	M12x32
9121 5102-51	80	45	84,75	165	14	48,5	334,5	M12x32

NOTE!

Please refer to the table on page 25 for suitable motors with worm drive gears.

Permitted shaft loadings

Basic motors

Max permitted load on output shaft for basic motors (based on 10,000,000 revolutions of the output shaft, with 90% probable service life for ball bearings).

	F_{ax} N	F_{rad} N	a mm
P1V-A160A0900	600	1000	15
P1V-A260A0700	700	1400	20
P1V-A360A0600	900	1900	25

F_{rad} = Radial loading (N)

F_{ax} = Axial loading (N)

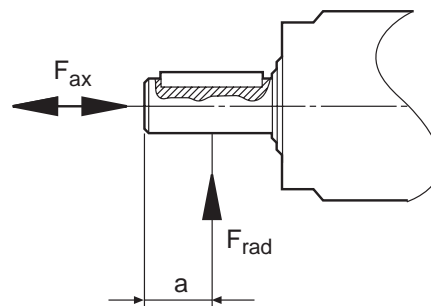

Fig. 1: Loading on output shaft.

Motors with planetary gears

The following calculations should be used to determine the loading on the output shaft bearing, if a service life of 10,000,000 revolutions of the output shaft is to be obtained with 90% probability.

$$F_{ax} = \max 0,24 \times F_{rad}$$

$$M = \pm F_{ax} \times r \pm F_{rad} \times (X + K)$$

Where M and K are found in the table below

	M Nm	K N
P1V-A160B120	2651	0,031
P1V-A160B060	2651	0,031
P1V-A160B019	7385	0,040
P1V-A160B010	7385	0,040
P1V-A260B120	2651	0,031
P1V-A260B060	2651	0,031
P1V-A260B019	7385	0,040
P1V-A360B096	7385	0,040
P1V-A360B048	7385	0,040

M Max. torque loading on output shaft (Nm)

r Distance from centre of output shaft to axial load (m)

X Distance from collar to radial load (m)

F_{rad} Radial loading (N)

F_{ax} Axial loading (N)

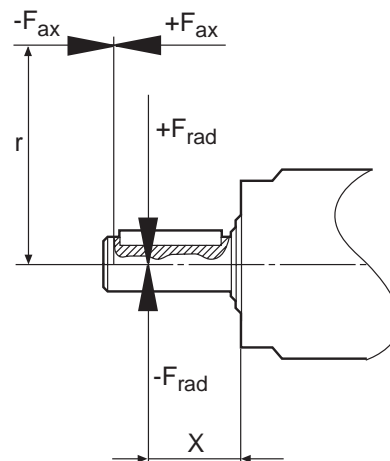

Fig 2: Load and braking torque on output shaft of planetary gear

Motors with helical gear or worm gear

Radial forces

Depending on the application, the drive shaft of the gearbox can be subjected to various radial forces, which can be calculated as follows:

$$F_{rad} = 2000 \times M \times K_r / d$$

F_{rad}	Radial force (N)
M	Torque (Nm)
d	Diameter of wheel, pulley, sprocket or gear wheel (mm)
$K_r = 1$	Sprocket constant
$K_r = 1.25$	Gear wheel constant
$K_r = 1.5 - 2.5$	Vee-belt pulley constant

Depending on the point of application of the force (please refer to the adjacent figure), the following two cases are found:

- The force is applied to the centre of the output shaft, as in figure 3. This value can be read off on the table below, where consideration must be given to the following:

$$F_{radc} \leq F_{rt}$$

- The force is applied at a distance x , as in figure 4. This value can be calculated as follows:

$$F_{radx} = F_{rt} \times a / (b + X) \text{ g\u00e4ller f\u00f6r } L/2 < X < c$$

F_{rt}	Permissible radial force on centre of output-shaft (N)
a	Gear constant
b	Gear constant
c	Gear constant
X	Distance from shoulder on shaft to point of application of force (mm)

All values are found in the table below.
The following should be considered, however:

$$F_{radc} \leq F_{radx}$$

Table, Motor with helical gear

Motor	a	b	c	F_{rt} N
P1V-A160■0066••	46,0	26,0	450	1130
P1V-A160■0032••	54,5	29,5	550	2480
P1V-A160■0014••	60,5	30,5	750	4710
P1V-A160■0008••	69,0	34,0	850	6620
P1V-A160■0004••	80,5	40,5	900	10000
P1V-A160■0003••	98,5	48,5	1000	16000
P1V-A260■0080••	46,0	26,0	450	660
P1V-A260■0052••	54,5	29,5	550	2110
P1V-A260■0025••	60,5	30,5	750	3850
P1V-A260■0011••	69,0	34,0	850	5660
P1V-A260■0006••	80,5	40,5	900	10000
P1V-A260■0003••	98,5	48,5	1000	16000
P1V-A360■0105••	54,5	29,5	550	1640
P1V-A360■0052••	54,5	29,5	550	2110
P1V-A360■0025••	69,0	34,0	850	4280
P1V-A360■0013••	80,5	40,5	900	6890
P1V-A360■0006••	98,5	48,5	1000	16000
P1V-A360■0003••	131,0	61,0	1500	35000

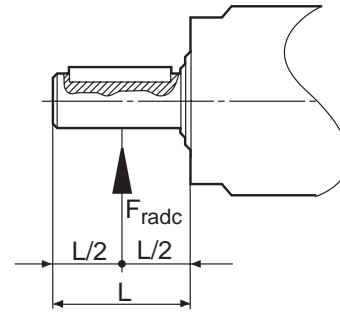

Fig. 3: Force applied at centre of shaft

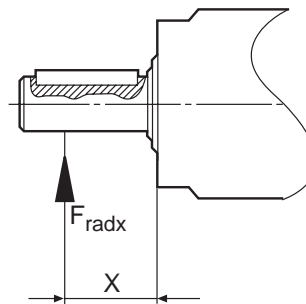

Fig. 4: Force applied at distance X

Axial forces

The maximum permissible axial force can be calculated as follows:

$$F_{ax} = F_{rt} \times 0,2$$

Table, Motor with worm gear

Motor	a	b	F_{rt} N
P1V-A160■0043••	99	69	3450
P1V-A160■0020••	132	102	4700
P1V-A160■0010••	147	117	7000
P1V-A160■0008••	147	117	7000
P1V-A260■0050••	99	69	3450
P1V-A260■0022••	147	117	7000
P1V-A260■0013••	147	117	7000
P1V-A260■0008••	182	142	13800
P1V-A360■0050••	132	102	4700
P1V-A360■0022••	147	117	7000
P1V-A360■0013••	171	134	8000
P1V-A360■0006••	182	142	13800

Service kits for basic motor

The following kits are available for the basic motors, consisting of vanes, O-rings and springs:

Service kit, vanes for intermittent lubrication-free operation

For motor	Order code
P1V-A160A0900	9121 7206-30
P1V-A260A0700	9121 7206-31
P1V-A360A0600	9121 7206-32

Service kit, vanes for continuous lubrication-free operation, option "C"

For motor	Order code
P1V-A160AC900	9121 7206-33
P1V-A260AC700	9121 7206-34
P1V-A360AC600	9121 7206-35